



www.apc-valve.com



Ningjin APC Industries Co.,Ltd

Add: No.18 Taishan Road,Ningjin,Shandong,P.R.China 253400
Tel: +86-534-5216788 / 5571078
Fax: +86-534-5216766 / 5571066
Website: www.apc-valve.com
E-mail: njcuishusheng@vip.163.com

NINGJIN APC INDUSTRIES®



About Us



Ningjin APC Industries, a leading manufacturer specializing in development and production of Fire Protection Valves, Industrial Valves, and Marine Valves in North China, was established in 1997 as well as the valves research center which collects more than 30 engineers, including 10 senior engineers and 2 American experts.

APC Industries possesses its own foundry, machining workshop, coating workshop, assembling workshop, and quality control system. With the advanced manufacturing facilities and experience from daily production practice, we can offer our customers OEM/ODM Service.

Under the management of ISO9001, APC has won many international certificates, like UL/CUL, FM, VDS, NSF61/372 in Fire Protection Industry, and NSF61/372, CE, DNV, LR, certificates for Industrial Valves and Marine Valves.

APC's first stage of UL/FM Fire Protection Products includes the following products

- 300PSI Grooved Butterfly Valve
- 300PSI Wafer Butterfly Valve
- 175PSI/300PSI Backflow Butterfly Valve
- OS&Y Gate Valve, both 200PSI and 300PSI, including Flanged End, Flanged*Grooved, and Grooved End type
- NRS Gate Valve, both 200PSI and 300PSI, including Flanged End, Flanged*Grooved, and Grooved End type
- 300PSI Swing Check Valve, Flanged Type
- 350PSI Swing Check Valve, including Flanged End, Flanged*Grooved, Grooved*Flanged, and Grooved End type
- Indicator Post, both vertical and wall type
- Fire Hydrant
- Wet Alarm Check Valve
- Air Release Valve
- Vane Type Water Flow Switch
- Pressure Switch
- Pressure Gauge



Butterfly Valve

Model: WD-371X/WD-371Y

Butterfly Valve c/w Signal Gearbox – Wafer End

Technical Features

- Flange Standard: ANSI 125 / 150, DIN2501 PN10/16
- Connection: Wafer End
- Sizes: 2", 2½", 3", 4", 5", 6", 8", 10", 12"
- Approvals: UL, CUL, FM, NSF / ANSI 61 & NSF / ANSI 372
- Maximum Working Pressure: 300 PSI (Maximum Testing Pressure: 600 PSI) conforms to UL1091 & ULC / ORD-C1091 & FM 1112
- Maximum Working Temperature: 80°C / 176°F
- Application: Indoor & Outdoor Use, Fire inflow water, drain pipe, high-rising building fire fighting system, industrial factory building fire protection system
- Coating Details: Epoxy coated interior and exterior by Electrostatic Spray or coating upon request
- Disc: Ductile Iron EPDM Rubber Encapsulated
- Top Flange Standard: ISO 5211
- Certified lead-free by NSF / ANSI 61 & NSF / ANSI 372 is available



Butterfly Valve

Model: WD-371X/WD-371Y

3D Pictures

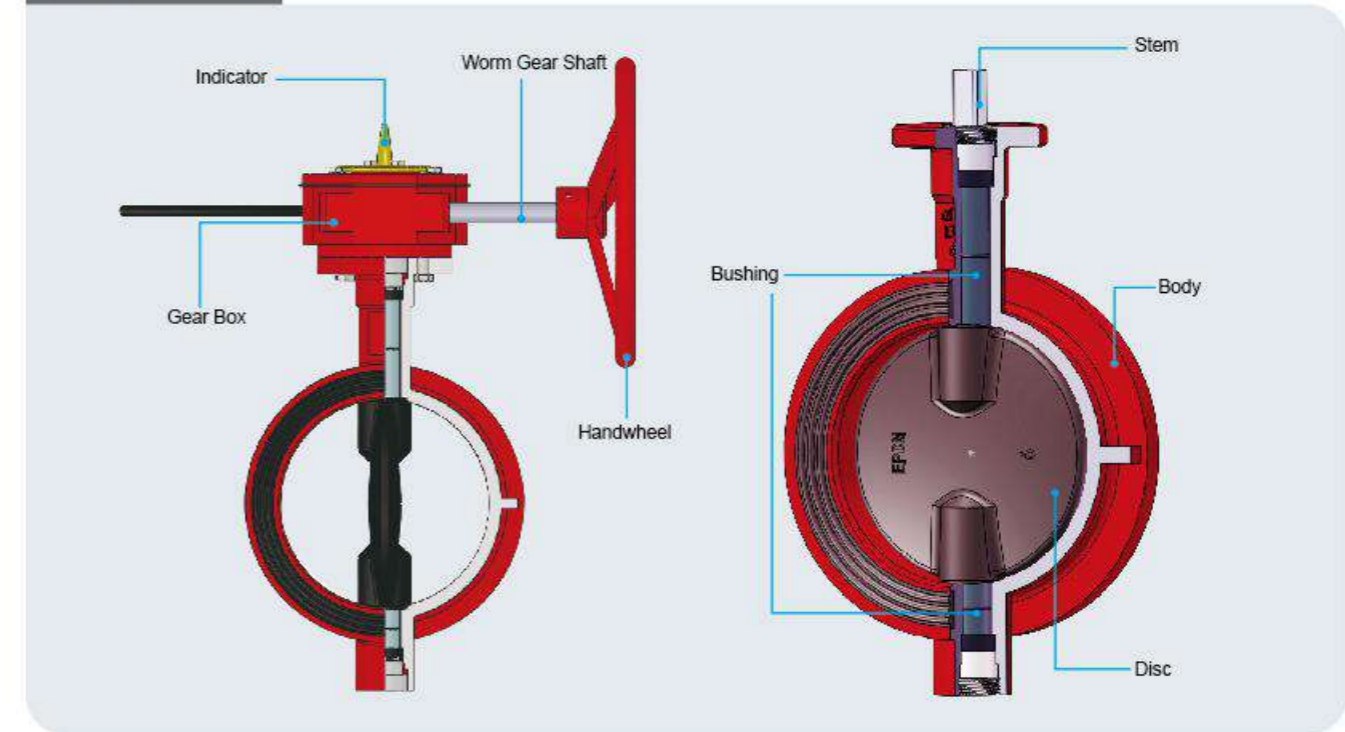

Valve Material List

NO.	Description	Material
1	Upper Shaft Sealing Nut	WCB
2	Shaft Seal	EPDM
3	Body	Ductile Iron
4	Upper Shaft	416 Stainless Steel
5	Disc+Rubber Seat	Ductile Iron+EPDM
6	Lower Shaft	416 Stainless Steel
7	Lower Shaft Sealing Nut	WCB
8	End Face Seal	EPDM
9	Stem Bushing	PTFE / C95400
10	O-Ring	EPDM
11	Gearbox	

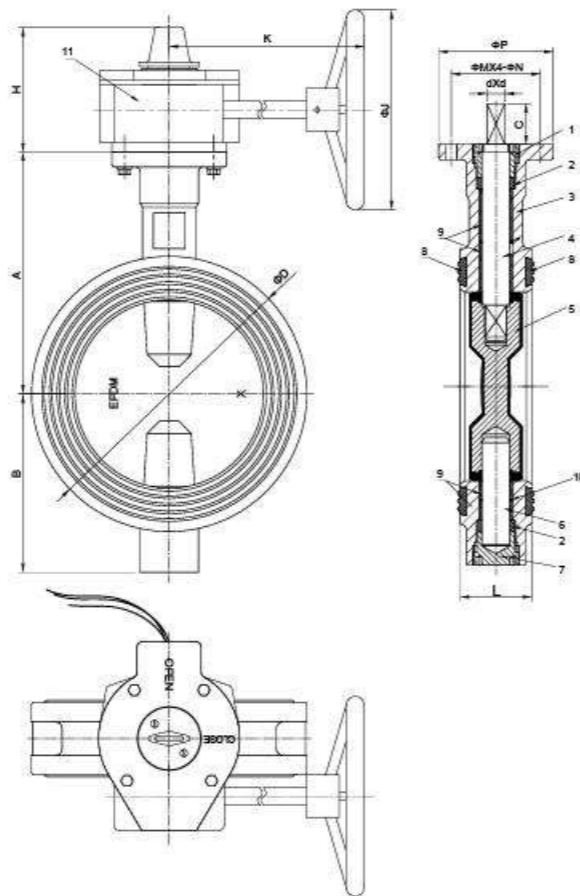

Dimensions

Size	A	B	C	D	H	K	J	P	M	N	d	L
2"	110	85	32	100	111	153	218	152	90	70	9	42
2½"	125	95	32	112	111	153	218	152	90	70	9	44.2
3"	140	100	32	120	111	153	218	152	90	70	9	45.3
4"	160	100	32	161	111	153	218	152	90	70	9	52
5"	170	125	32	182	111	153	218	152	90	70	9	54.4
6"	190	140	32	216	111	153	218	200	90	70	9	55.8
8"	230	175	32	260	126	210	232	300	125	102	12	60.5
10"	260	200	45	320	126	210	232	300	125	102	12	66.5
12"	300	240	45	375	161	249	350	150	125	14	26	76.9

Gearbox Drawing

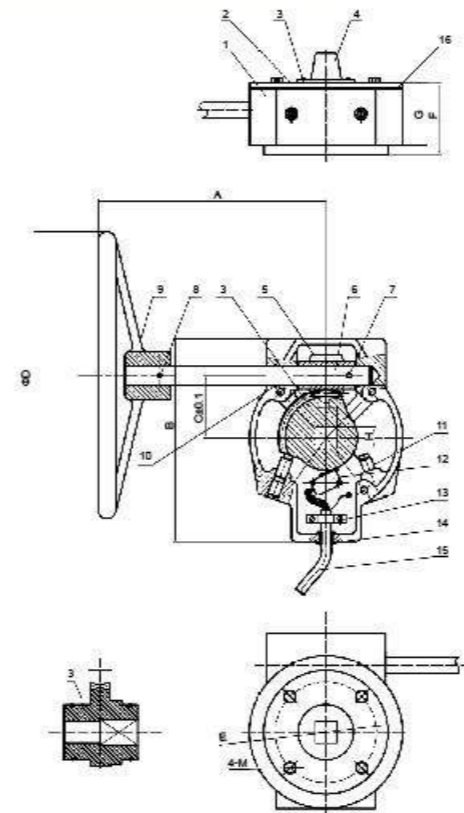

Gearbox Material List

NO.	Description	Material
1	Gear Body	Ductile Iron
2	Gear Cover	Ductile Iron
3	Worm Wheel	Ductile Iron
4	Indicator	Ductile Iron
5	Worm	Steel
6	Handwheel Shaft	Steel
7	Pin	416 Stainless Steel
8	Pin	416 Stainless Steel
9	Handwheel	Ductile Iron
10	O-Ring	EPDM
11	Set Screw	Steel
12	Signal Switch	Switch Assembly
13	Clip	Nylon
14	Sealing Ring	EPDM
15	Wire	Wire
16	Gasket	EPDM

Dimensions

Gearbox Valve	A	B	C	D	E	F	G	H	M
24:1 2"-2½"	153	218	164	45	152	70	65	58	10 M8
24:1 3"	153	218	164	45	152	70	65	58	11 M8
24:1 4"-5"	153	218	164	45	152	70	65	58	14 M8
24:1 6"	153	218	164	45	200	70	65	58	16 M8
30:1 8"	210	232	205	63	300	102	79	67	19 M10
30:1 10"	210	232	205	63	300	102	79	67	22 M10
80:1 12"	249	284	120	350	125	118	110	24	M12

Butterfly Valve

Model: GD-381X/GD-381Y

Butterfly Valve

Model: GD-381X/GD-381Y

Butterfly Valve c/w Signal Gearbox – Grooved End

Technical Features

- Conforms: ANSI / AWWA C606 or Metric Standard Clear Waterway design
- Connection: Grooved End
- Sizes: 2", 2½", 3", 4", 5", 6", 8", 10", 12"
- Approvals: UL, CUL, FM, NSF / ANSI 61 & NSF/ ANSI 372
- Maximum Working Pressure: 300 PSI (Maximum Testing Pressure: 600 PSI) conforms to UL1091 & ULC / ORD-C1091 & FM 1112
- Maximum Working Temperature: 80°C / 176°F
- Application: Indoor & Outdoor Use, Fire inflow water, drain pipe, high-rising building fire fighting system, industrial factory building fire protection system
- Coating Details: Epoxy coated interior and exterior by Electrostatic Spray or coating upon request
- Disc: Ductile Iron EPDM Rubber Encapsulated
- Top Flange Standard: ISO 5211
- Certified lead-free by NSF / ANSI 61 & NSF / ANSI 372 is available



3D Pictures

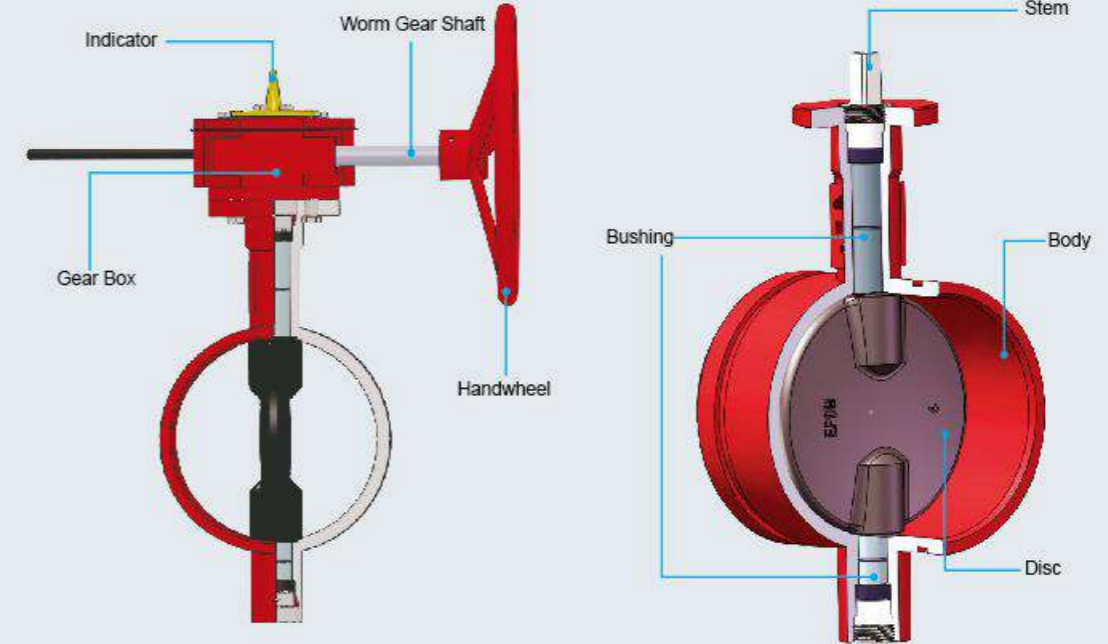

Valve Material List

NO.	Description	Material
1	Upper Shaft Sealing Nut	WCB
2	Shaft Seal	EPDM
3	Body	Ductile Iron
4	Upper Shaft	416 Stainless Steel
5	Disc+Rubber Seat	Ductile Iron+EPDM
6	Lower Shaft	416 Stainless Steel
7	Lower Shaft Sealing Nut	WCB
8	Stem Bushing	PTFE / C95400
9	O-Ring	EPDM
10	Gearbox	

Dimensions

Size	A	B	C	D	E	F	G	H	K	J	M	N	d	L		
2"	110	85	32	60.3	57.15	15.9	7.9	111	153	218	152	90	9	10	81 88	
2½"	125	95	32	73 76.1	69.1 72.3	15.9	7.9	111	153	218	152	90	9	10	96.4	
3"	140	100	32	88.9	84.9	15.9	7.9	111	153	218	152	90	9	11	97	
4"	160	100	32	114.3	110.1	15.9	9.5	111	153	218	152	90	9	14	115.1	
5"	170	125	32	139.7 141.3	135.5 137	15.9	9.5	111	153	218	152	90	9	14	132.4 148	
6"	190	140	32	165.1 168.3	160.9 164	15.9	9.5	111	153	218	200	90	70	9	16 148	
8"	230	175	32	219.1 216.3	214.4 211.6	19	11.1	126	210	232	300	125	102	12	19 147.4	
10"	260	200	45	267.4 273	262.6 268.3	19	12.7	126	210	232	300	125	102	12	24	159
12"	300	240	45	318.5 323.8	312.9 318.3	19	12.7	161	249	350	150	125	14	26	165	

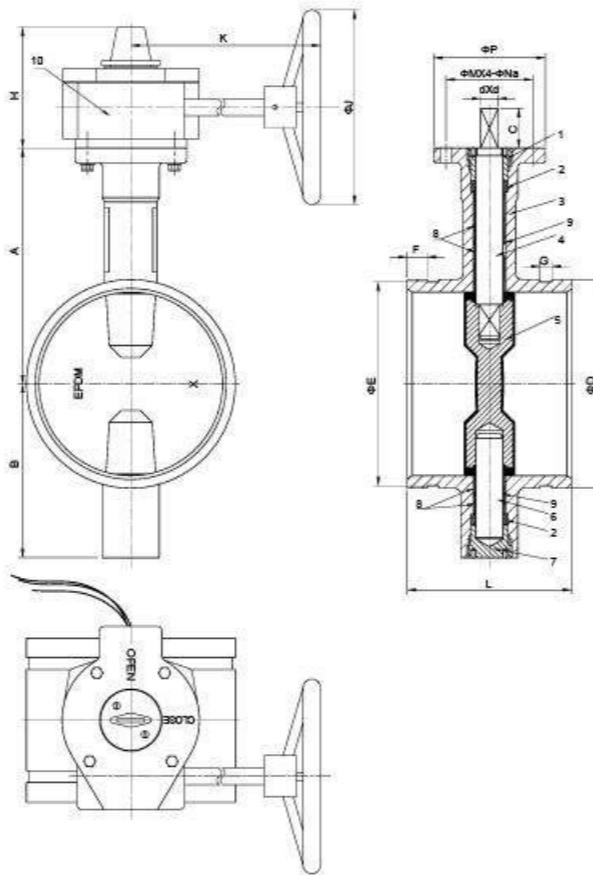

Gearbox Drawing

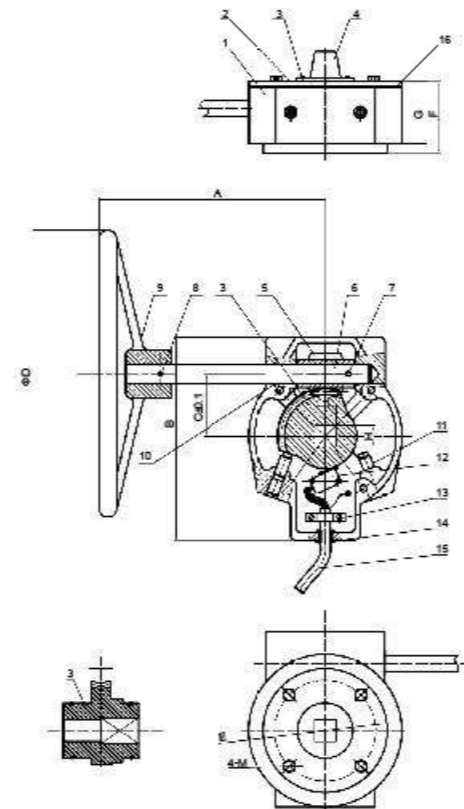

Gearbox Material List

NO.	Description	Material
1	Gear Body	Ductile Iron
2	Gear Cover	Ductile Iron
3	Worm Wheel	Ductile Iron
4	Indicator	Ductile Iron
5	Worm	Steel
6	Handwheel Shaft	Steel
7	Pin	416 Stainless Steel
8	Pin	416 Stainless Steel
9	Handwheel	Ductile Iron
10	O-Ring	EPDM
11	Set Screw	Steel
12	Signal Switch	Switch Assembly
13	Clip	Nylon
14	Sealing Ring	EPDM
15	Wire	Wire
16	Gasket	EPDM

Dimensions

Gearbox	Valve	A	B	C	D	E	F	G	H	M	
24:1	2"-2½"	153	218	164	45	152	70	65	58	10	M8
24:1	3"	153	218	164	45	152	70	65	58	11	M8
24:1	4"-5"	153	218	164	45	152	70	65	58	14	M8
24:1	6"	153	218	164	45	200	70	65	58	16	M8
30:1	8"	210	232	205	63	300	102	79	67	19	M10
30:1	10"	210	232	205	63	300	102	79	67	22	M10
80:1	12"	249	284	120	350	125	118	110	24	M12	

Backflow Butterfly Valve Model: HGD-381X-175/HFGD-381X-175/HGD-381X/HFGD-381X

Butterfly Valve c/w Signal Gearbox – Grooved End & Grooved * Flanged End

Technical Features

- Conforms: ANSI / AWWA C606 or Metric Standard Clear Waterway design
- Connections: Grooved End / Grooved * Flanged End / Flanged * Grooved End
- Sizes: 2½", 3", 4", 6", 8", 10"
- Approvals: UL, CUL, FM, NSF/ANSI 61 & NSF/ANSI 372
- Maximum Working Pressure: 175 PSI / 300 PSI (Maximum Testing Pressure: 600 PSI) conforms to UL1091 & ULC / ORD-C1091 & FM1112
- Maximum Working Temperature: 80°C / 176°F
- Application: Indoor & Outdoor Use, Fire inflow water, drain pipe, high-rising building fire fighting system, industrial factory building fire protection system
- Coating Details: Epoxy coated interior and exterior by Electrostatic Spray or coating upon request
- Disc: Ductile Iron EPDM Rubber Encapsulated
- Top Flange Standard: ISO 5211
- Certified lead-free by NSF/ANSI 61 & NSF/ANSI 372 is available



Valve Material List

NO.	Description	Material
1	Upper Shaft Sealing Nut	WCB
2	Shaft Seal	EPDM
3	Body	Ductile Iron
4	Upper Shaft	416 Stainless Steel
5	Disc+Rubber Seat	Ductile Iron+EPDM
6	Lower Shaft	416 Stainless Steel
7	Lower Shaft Sealing Nut	WCB
8	Stem Bushing	PTFE / C95400
9	Signal Gearbox	
10	Plug	C95400

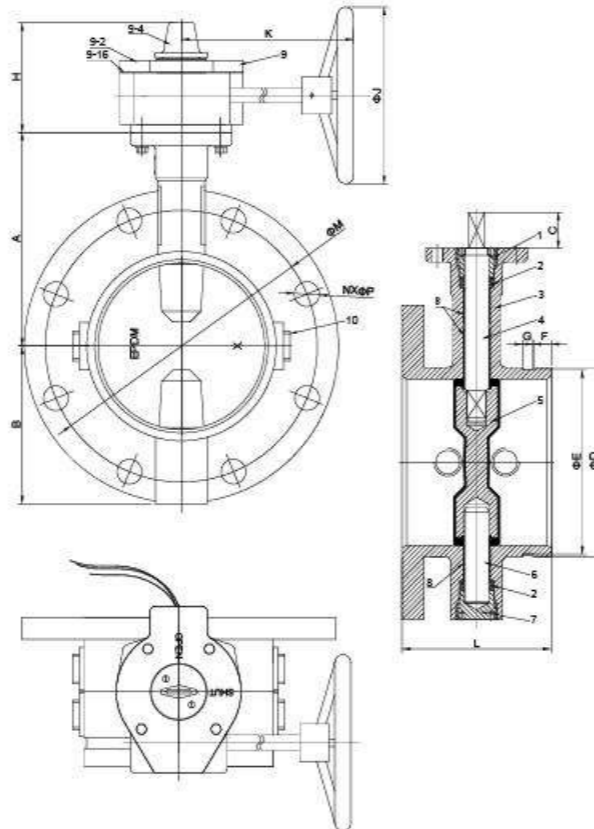

Dimensions

Size	A	B	C	D	E	F	G	H	K	J	L	M	N	P
2½"	125	95	32	73	69.1	15.9	7.9	111	153	152	152.4	139.7	4	19
3"	140	100	32	88.9	84.9	15.9	7.9	111	153	152	158.8	152.5	4	19
4"	160	100	32	114.3	110.1	15.9	9.5	111	153	152	168.4	190.5	8	19
6"	190	140	32	165.1	160.9	15.9	9.5	111	153	200	177.8	241.3	8	22
8"	230	175	32	219.1	214.4	19	11.1	126	230	290	203	298.5	8	22
10"	260	200	45	267.4	262.6	19	12.7	126	230	290	203	362	12	25.4

Butterfly Valve

Model: WD-371G/WD-371L

Butterfly Valve with Gearbox / Lever – Wafer End

Technical Features

- Flange Standard: ANSI 125 / 150, DIN2501 PN10 / 16
- Connection: Wafer End
- Sizes: 2", 2½", 3", 4", 5", 6", 8", 10", 12"
- Maximum Working Pressure: 300 PSI (Maximum Testing Pressure: 600 PSI) conforms to UL1091 & ULC / ORD-C1091 & FM 1112
- Maximum Working Temperature: 80°C / 176°F
- Application: Indoor & Outdoor Use, Fire inflow water, drain pipe, high-rising building fire fighting system, industrial factory building fire protection system
- Coating Details: Epoxy coated interior and exterior by Electrostatic Spray or coating upon request
- Disc: Ductile Iron EPDM Rubber Encapsulated
- Top Flange Standard: ISO 5211
- Certified lead-free by NSF / ANSI 61 & NSF / ANSI 372 is available



Valve Material List

NO.	Description	Material
1	Upper Shaft Sealing Nut	WCB
2	Shaft Seal	EPDM
3	Body	Ductile Iron
4	Upper Shaft	416 Stainless Steel
5	Disc+Rubber Seat	Ductile Iron+EPDM
6	Lower Shaft	416 Stainless Steel
7	Lower Shaft Sealing Nut	WCB
8	End Face Seal	EPDM
9	Stem Bushing	PTFE / C95400
10	O-Ring	EPDM
11	Lever	
12	Gearbox	

Dimensions

Size	A	B	C	D	H1	H2	K1	K2	J	P	M	N	d	L
2"	110	85	32	100	32	65	267	151	152	90	70	9	10	42
2½"	125	95	32	112	32	65	267	151	152	90	70	9	10	44.2
3"	140	100	32	120	32	65	267	151	152	90	70	9	11	45.3
4"	160	100	32	161	32	65	267	151	152	90	70	9	14	52
5"	170	125	32	182	32	65	267	151	152	90	70	9	14	54.4
6"	190	140	32	216	32	65	267	146	200	90	70	9	16	55.8
8"	230	175	32	260	37	77	267	233	290	125	102	12	19	60.5
10"	260	200	45	320	/	77	/	233	290	125	102	12	22	66.5
12"	300	240	45	375	/	77	/	226	290	150	125	14	26	76.9

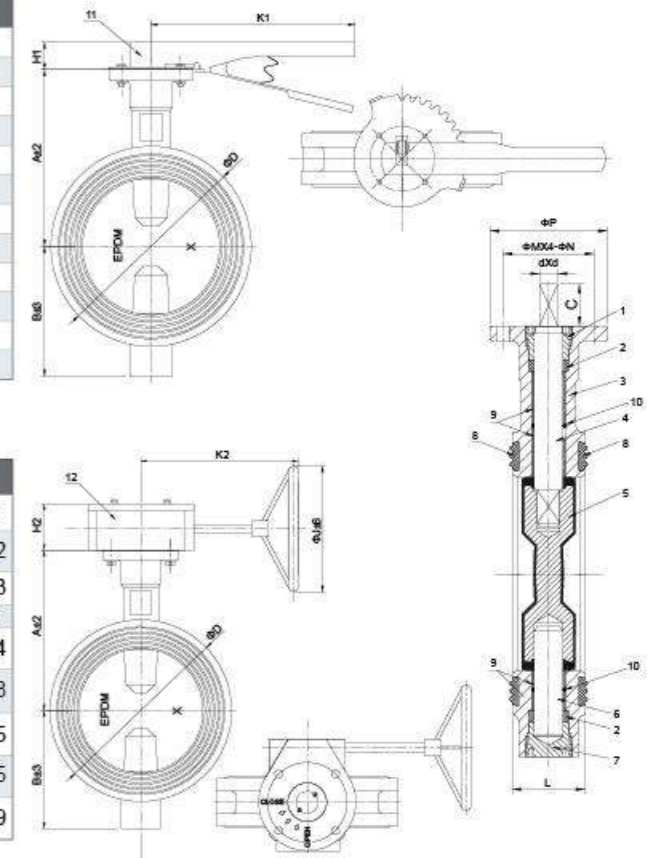

Butterfly Valve with Gearbox – Grooved End

Technical Features

- Conforms: ANSI / AWWA C606 or Metric Standard Clear Waterway design
- Connection: Grooved End
- Sizes: 2", 2½", 3", 4", 5", 6", 8", 10", 12"
- Maximum Working Pressure: 300 PSI (Maximum Testing Pressure: 600 PSI) conforms to UL1091 & ULC / ORD-C1091 & FM 1112
- Maximum Working Temperature: 80°C / 176°F
- Application: Indoor & Outdoor Use, Fire inflow water, drain pipe, high-rising building fire fighting system, industrial factory building fire protection system
- Coating Details: Epoxy coated interior and exterior by Electrostatic Spray or coating upon request
- Disc: Ductile Iron EPDM Rubber Encapsulated
- Top Flange Standard: ISO 5211
- Certified lead-free by NSF / ANSI 61 & NSF / ANSI 372 is available



Valve Material List

NO.	Description	Material
1	Upper Shaft Sealing Nut	WCB
2	Shaft Seal	EPDM
3	Body	Ductile Iron
4	Upper Shaft	416 Stainless Steel
5	Disc+Rubber Seat	Ductile Iron+EPDM
6	Lower Shaft	416 Stainless Steel
7	Lower Shaft Sealing Nut	WCB
8	Stem Bushing	PTFE / C95400
9	O-Ring	EPDM
10	Gear box	

Dimensions

Size	A	B	C	D	E	F	G	H	K	J	P	M	N	d	L
2"	110	85	32	60.3	57.15	15.9	7.9	65	151	152	90	70	9	10	81.88
2½"	125	95	32	73	69.1	15.9	7.9	65	151	152	90	70	9	10	96.4
3"	140	100	32	88.9	84.9	15.9	7.9	65	151	152	90	70	9	11	97
4"	160	100	32	114.3	110.1	15.9	9.5	65	151	152	90	70	9	14	115.1
5"	170	125	32	139.7	135.5	15.9	9.5	65	151	152	90	70	9	14	132.4
6"	190	140	32	165.1	160.9	15.9	9.5	65	146	200	90	70	9	16	148
8"	230	175	32	219.1	214.4	19	11.1	77	233	290	125	102	12	19	133
10"	260	200	45	267.4	262.6	19	12.7	77	233	290	125	102	12	22	159
12"	300	240	45	318.5	312.9	19	12.7	77	226	290	150	125	14	26	165

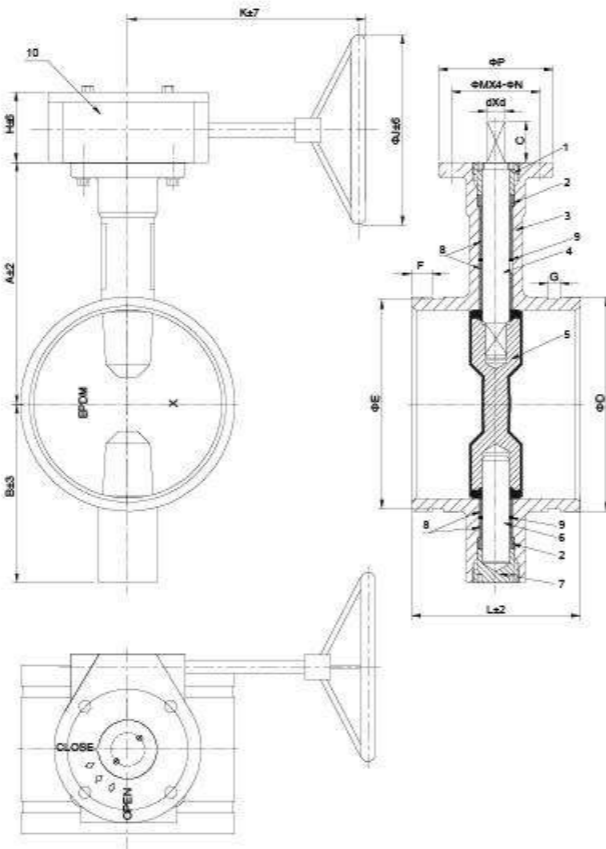

Butterfly Valve with Lever - Grooved End

Technical Features

- Conforms: ANSI / AWWA C606 or Metric Standard Clear Waterway design
- Connection: Grooved End
- Sizes: 2", 2½", 3", 4", 5", 6", 8"
- Maximum Working Pressure: 300 PSI (Maximum Testing Pressure: 600 PSI) conforms to UL1091 & ULC / ORD-C1091 & FM 1112
- Maximum Working Temperature: 80°C / 176°F
- Application: Indoor & Outdoor Use, Fire inflow water, drain pipe, high-rising building fire fighting system, industrial factory building fire protection system
- Coating Details: Epoxy coated interior and exterior by Electrostatic Spray or coating upon request
- Disc: Ductile Iron EPDM Rubber Encapsulated
- Top Flange Standard: ISO 5211
- Certified lead-free by NSF / ANSI 61 & NSF / ANSI 372 is available



Valve Material List

NO.	Name	Material
1	Upper Shaft Sealing Nut	WCB
2	Shaft Seal	EPDM
3	Body	Ductile Iron
4	Upper Shaft	416 Stainless Steel
5	Disc+Rubber Seat	Ductile Iron+EPDM
6	Lower Shaft	416 Stainless Steel
7	Lower Shaft Sealing Nut	WCB
8	Stem Bushing	PTFE / C95400
9	O-ring	EPDM
10	Lever	Malleable Iron

Dimensions

Size	A	B	C	D	E	F	G	H	K	P	M	N	d	L
2"	110	85	32	60.3	57.2	15.9	7.9	32	267	90	70	9	10	81.88
2½"	125	95	32	73	69.1	15.9	7.9	32	267	90	70	9	10	96.4
3"	140	100	32	88.9	84.9	15.9	7.9	32	267	90	70	9	11	97
4"	160	100	32	114.3	110.1	15.9	9.5	32	267	90	70	9	14	115.1
5"	170	125	32	139.7	135.5	15.9	9.5	32	267	90	70	9	14	132.4
6"	190	140	32	165.1	160.9	15.9	9.5	32	267	90	70	9	16	148
8"	230	175	37	216.3	211.6	19	11.1	37	353	125	102	12	19	147.4

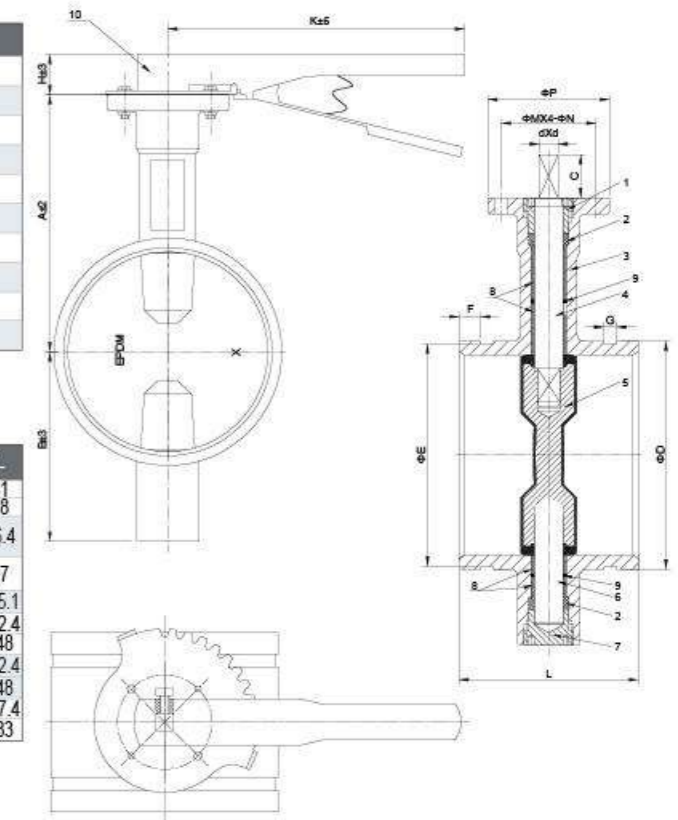

NINGJIN APC INDUSTRIES CO.,LTD.offers a complete package of resilient wedge gate valve with excellent Ductile Iron structure and stable sealing capability and popular end connection options

APC Resilient Wedge Gate Valve Features

- Conforms: ANSI / AWWA C515
- Approvals: UL, CUL, FM, NSF/ ANSI 61 & NSF/ ANSI 372 Certified lead-free
- Maximum Working Temperature: 80°C / 176°F
- Coating: Epoxy coated interior and exterior by Electrostatic Spray or Coating upon request

Application

- Outdoor and Indoor Fire inflow water, water supply and drainage, potable water, high-rising building fire fighting system, industrial factory building fire protection system.
- All OS&Y gate valves have tamper resistant handwheel nuts as well as pre-grooved stems enabling seamless tamper switch installation.
- All NRS gate valves are available with operated nut installed with vertical indicator post and wall type indicator.

Advantages

- Valve body, bonnet, disc, gland, & operating nut are all produced with ductile iron material with superior strength-to-weight ratios to guarantee high quality.
- Long service life with resilient seat cycling test at least 5000 times.
- The bottom of gate valve adopt straight-through design, no foreign matter store to make sure smooth flow and reliable sealing.
- Self-sealing design between the bonnet and body make the sealing more tight when pressure is higher within the allowable range.
- Multiple O-ring sealing structure to protect the stem under pressure during operation and maintenance , it causes no damage to the operator.

A full range UL/FM Gate Valves to meet customers' different requirements

- UL/FM OS&Y Gate valve (200psi & 300psi)
- Flange x Flange
- Flange x Groove
- Groove x Groove
- UL/FM NRS Gate valve (200psi & 300psi)
- Flange x Flange
- Groove x Groove
- MJ x Flange
- Flange x Groove
- MJ x MJ

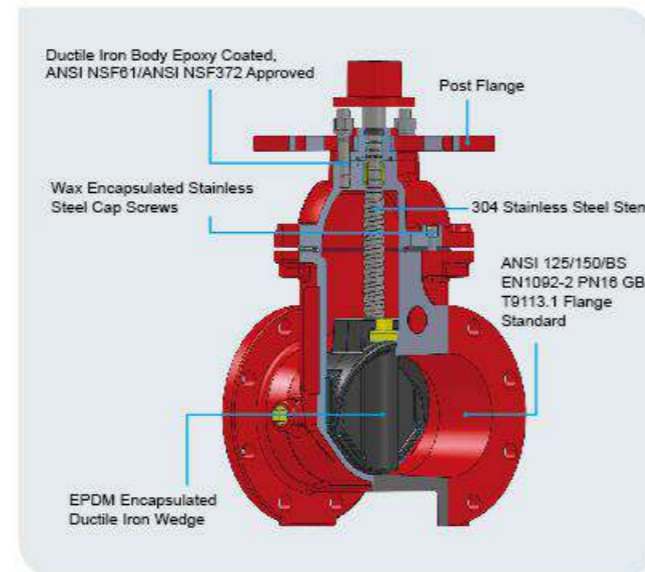
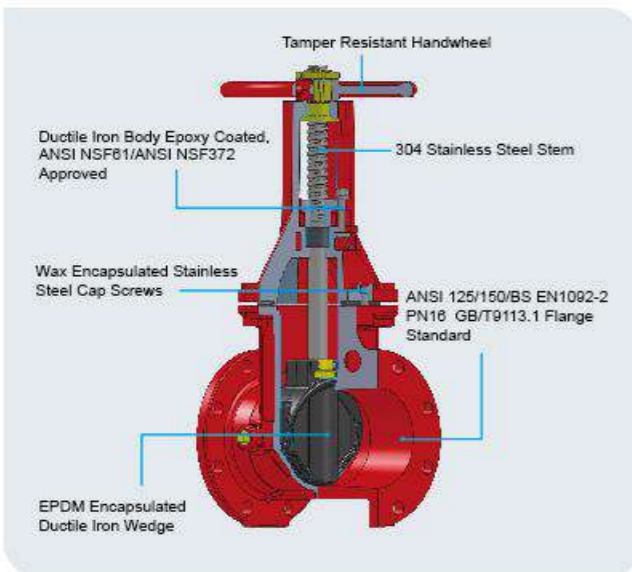

UL / FM OS&Y Gate Valves

<p>Z41 Flange ANSI, BS, DIN, GB 2"/DN50-16"/DN400 14Bar/200psi UL/FM/NSF61/NSF372</p>	<p>Z481 Flange x Groove ANSI, BS, DIN, GB 2"/DN50-12"/DN300 14Bar/200psi UL/FM/NSF61/NSF372</p>	<p>Z81 Groove ANSI, BS, DIN, GB 2"/DN50-12"/DN300 14Bar/200psi UL/FM/NSF61/NSF372</p>
<p>Z41-300 Flange ANSI, BS, DIN, GB 2 1/2"/DN65-12"/DN300 21Bar/300psi UL/FM/NSF61/NSF372</p>	<p>Z41-300A Flange ANSI, BS, DIN, GB 2 1/2"/DN65-12"/DN300 21Bar/300psi UL/FM/NSF61/NSF372</p>	<p>Z81-300 Groove ANSI, BS, DIN, GB 2 1/2"/DN65-12"/DN300 21Bar/300psi UL/FM/NSF61/NSF372</p>
<p>Z81-300A Groove ANSI, BS, DIN, GB 2 1/2"/DN65-12"/DN300 21Bar/300psi UL/FM/NSF61/NSF372</p>	<p>Z481-300 Flange X Groove ANSI, BS, DIN, GB 2 1/2"/DN65-12"/DN300 21Bar/300psi UL/FM/NSF61/NSF372</p>	<p>Z481-300A Flange X Groove ANSI, BS, DIN, GB 2 1/2"/DN65-12"/DN300 21Bar/300psi UL/FM/NSF61/NSF372</p>

UL / FM Non Rising Stem Gate Valves

<p>Z45 Flange ANSI, BS, DIN, GB 2"/DN50-12"/DN300 14Bar/200psi UL/FM/NSF61/NSF372</p>	<p>Z485 Flange X Groove ANSI, BS, DIN, GB 2"/DN50-12"/DN300 14Bar/200psi UL/FM/NSF61/NSF372</p>	<p>Z85 Groove ANSI, BS, DIN, GB 2"/DN50-12"/DN300 14Bar/200psi UL/FM/NSF61/NSF372</p>
<p>Z45-300 Flange ANSI, DIN, GB 2 1/2"/DN65-12"/DN300 21Bar/300psi UL/FM/NSF61/NSF372</p>	<p>Z45-300A Flange ANSI, DIN, GB 2"/DN50-12"/DN300 21Bar/300psi UL/FM/NSF61/NSF372</p>	<p>Z85-300 Groove ANSI, DIN, GB 2 1/2"/DN65-12"/DN300 21Bar/300psi UL/FM/NSF61/NSF372</p>
<p>Z85-300A Groove ANSI, DIN, GB 2 1/2"/DN65-12"/DN300 21Bar/300psi UL/FM/NSF61/NSF372</p>	<p>Z485-300 Flange X Groove ANSI, DIN, GB 2"/DN50-12"/DN300 21Bar/300psi UL/FM/NSF61/NSF372</p>	<p>Z485-300A Flange X Groove ANSI, DIN, GB 2 1/2"/DN65-12"/DN300 21Bar/300psi UL/FM/NSF61/NSF372</p>
<p>Z45-300FJA Flange X MJ ANSI, DIN, GB 2"/DN50-12"/DN300 21Bar/300psi UL/FM/NSF61/NSF372</p>	<p>Z45-300MJA MJ X MJ ANSI, DIN, GB 2"/DN50-12"/DN300 21Bar/300psi UL/FM/NSF61/NSF372</p>	

300PSI OS&Y Flanged End Gate Valve

Model: Z41-300

Resilient Wedge OS & Y Gate valve – Flanged End

Technical Features

- Nominal Pressure: 300PSI
- Flange Standard: ASME / ANSI B 16.1 Class 125 or ASME / ANSI B 16.42 Class 150 or BS EN 1092-2 PN 16 or GB / T9113.1
- Sizes: 2½", 3", 4", 5", 6", 8", 10", 12"
- Face to Face Standard : ASME B 16.10
- Approvals: UL, CUL, FM, NSF / ANSI 61 & NSF / ANSI 372, CCC
- Maximum Working Pressure: 300PSI (Maximum Testing Pressure: 600 PSI) conforms to UL 262, ULC / ORD C 262-92 , FM 1120 / 1130
- Maximum Working Temperature: 80°C / 176°F
- Coating Details: Epoxy coated interior and exterior by Electrostatic Spray or Coating upon request
- NPT plug on body with 2 operating nuts
- Certified lead-free by NSF / ANSI 61 & NSF / ANSI 372 is available

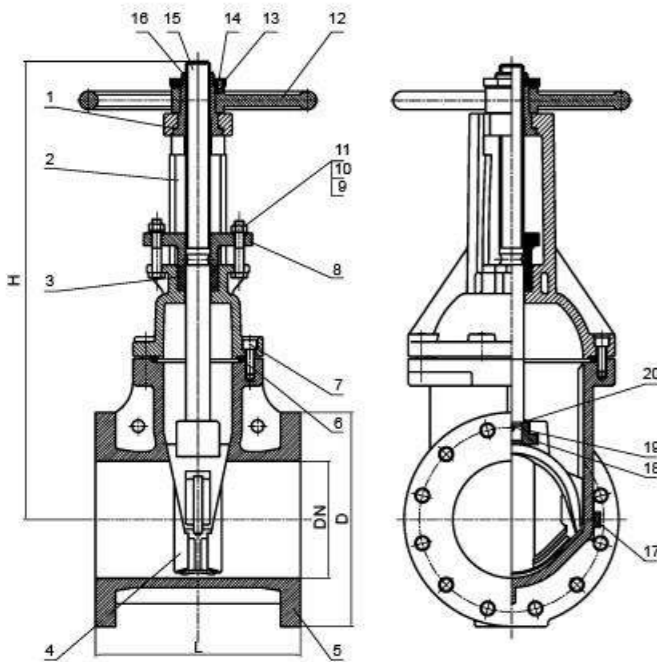

Dimensions

Size	DN	L	D	H
2½"	65	190	178	370
3"	80	203	191	420
4"	100	229	229	447
5"	125	254	254	547
6"	150	267	279	607
8"	200	292	343	754
10"	250	330	406	890
12"	300	356	483	1031

Valve Material List

NO.	Name	Material
1	Gasket	C95400
2	Bonnet	Ductile Iron
3	Packing	Graphite
4	Disc	Ductile Iron +EPDM
5	Body	Ductile Iron
6	Sealing Ring	EPDM
7	Bolt	Steel 1045
8	Gland	Ductile Iron
9	Nut	Steel 1045
10	Flat Washer	Steel 1045
11	Bolt	Steel 1045
12	Handwheel	Ductile Iron
13	Lock Nut	C95400
14	Locating Screw	Stainless Steel 304
15	Stem	Stainless Steel 304
16	Stem Nut	C95400
17	Plug	C95400
18	Lifting Nut	CF8
19	Pin	Stainless Steel 304
20	Sealing Ring	EPDM

300PSI OS&Y Grooved End Gate Valve

Model: Z81-300

Resilient Wedge OS & Y Gate valve – Grooved End

Technical Features

- Nominal Pressure: 300PSI
- Groove standard: Metric or ANSI / AWWA C606
- Face to Face Standard: ASME B16.10
- Sizes: 2½", 3", 4", 5", 6", 8", 10", 12"
- Approvals: UL, CUL, FM, NSF / ANSI 61 & NSF / ANSI 372
- Maximum Working Pressure: 300PSI (Maximum Testing Pressure: 600 PSI) conforms to UL 262, ULC / ORD C 262-92 , FM 1120 / 1130
- Maximum Working Temperature: 80°C / 176°F
- Coating Details: Epoxy coated interior and exterior by Electrostatic Spray or Coating upon request
- NPT plug on body with 2 operating nuts
- Certified lead-free by NSF / ANSI 61 & NSF / ANSI 372 is available

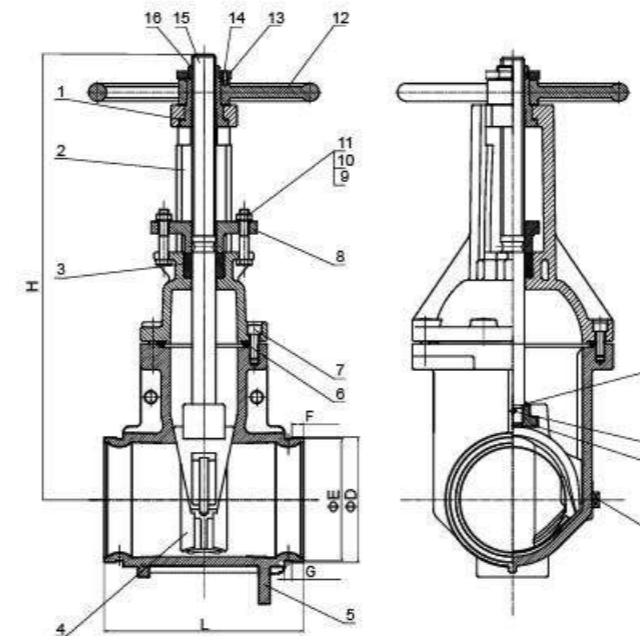

Dimensions

Size	DN	L	F	D	E	G	H
2½"	65	190	15.9	73 76.1	69.1 72.3	7.9	370
3"	80	203	15.9	88.9	84.9	7.9	420
4"	100	229	15.9	114.3	110.1	9.5	447
5"	125	254	15.9	139.7 141.3	135.5 137	9.5	547
6"	150	267	15.9	165.1 168.3	160.8 163.9	9.5	607
8"	200	292	19	216.3 219.1	211.6 214.3	11.1	754
10"	250	330	19	273	268.3	12.7	890
12"	300	356	19	323.9	318.3	12.7	1031

Valve Material List

NO.	Name	Material
1	Gasket	Stainless Steel 304 or C95400
2	Bonnet	Ductile Iron
3	Packing	Graphite
4	Disc	Ductile Iron +EPDM
5	Body	Ductile Iron
6	Sealing Ring	EPDM
7	Bolt	Stainless Steel 304 or Steel 1045
8	Gland	Ductile Iron
9	Nut	Stainless Steel 304 or Steel 1045
10	Flat Washer	Stainless Steel 304 or Steel 1045
11	Bolt	Stainless Steel 304 or Steel 1045
12	Handwheel	Ductile Iron
13	Lock Nut	C95400
14	Locating Screw	Stainless Steel 304 or Steel 1045
15	Stem	Stainless Steel 304 or C95400
16	Stem Nut	C95400
17	Plug	C95400
18	Lifting Nut	CF8/CF8M or C95400
19	Pin	Stainless Steel 304
20	Sealing Ring	EPDM

300PSI OS&Y Flanged X Grooved End Gate Valve Model: Z481-300

Resilient Wedge OS & Y Gate valve – Flanged x Grooved End

Technical Features

- Nominal Pressure: 300PSI
- Face to Face Standard: ASME B16.10
- Sizes: 2½", 3", 4", 5", 6", 8", 10", 12"
- Flange Standard: ASME / ANSI B16.1 Class 125 or ASME / ANSI B16.42 Class 150 or BS EN1092-2 PN16 or GB / T9113.1
- Groove Standard: Metric or ANSI / AWWA C606
- Approvals: UL, CUL, FM, NSF / ANSI 61 & NSF / ANSI 372
- Maximum Working Pressure: 300PSI (Maximum Testing Pressure: 600 PSI) conforms to UL262, ULC / ORD C262-92 , FM 1120 / 1130
- Maximum Working Temperature: 80°C / 176°F
- Coating Details: Epoxy coated interior and exterior by Electrostatic Spray or Coating upon request
- NPT plug on body with 2 operating nuts
- Certified lead-free by NSF / ANSI 61 & NSF / ANSI 372 is available

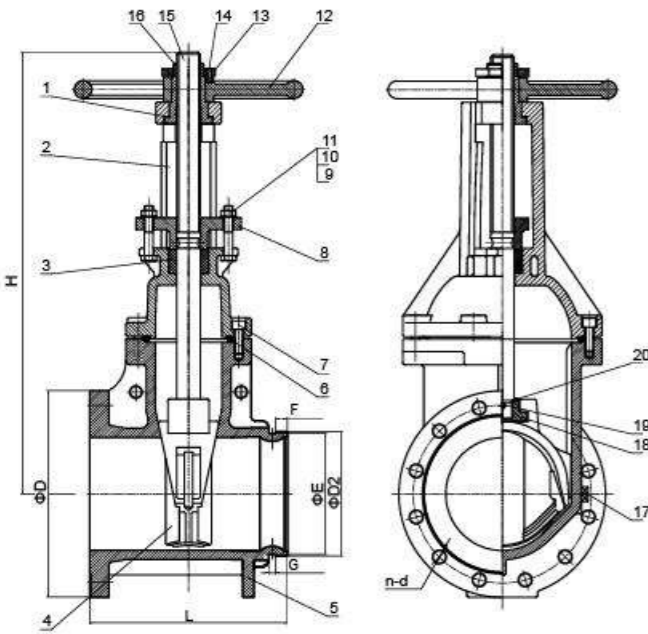

Valve Material List

NO.	Name	Material
1	Gasket	Stainless Steel 304 or C95400
2	Bonnet	Ductile Iron
3	Packing	Graphite
4	Disc	Ductile Iron +EPDM
5	Body	Ductile Iron
6	Sealing Ring	EPDM
7	Bolt	Stainless Steel 304 or Steel 1045
8	Gland	Ductile Iron
9	Nut	Stainless Steel 304 or Steel 1045
10	Flat Washer	Stainless Steel 304 or Steel 1045
11	Bolt	Stainless Steel 304 or Steel 1045
12	Handwheel	Ductile Iron
13	Lock Nut	C95400
14	Locating Screw	Stainless Steel 304 or Steel 1045
15	Stem	Stainless Steel 304 or C95400
16	Stem Nut	C95400
17	Plug	C95400
18	Lifting Nut	CF8 or C95400
19	Pin	Stainless Steel 304
20	Sealing Ring	EPDM

Dimensions

Size	DN	L	D	F	D2	E	G	H
2½"	65	190	178	15.9	73 76.1	69.1 72.3	7.9	370
3"	80	203	191	15.9	88.9	84.9	7.9	420
4"	100	229	229	15.9	114.3	110.1	9.5	447
5"	125	254	254	15.9	139.7 141.3	135.5 137	9.5	547
6"	150	267	279	15.9	165.1 168.3	160.8 163.9	9.5	607
8"	200	292	343	19	216.3 219.1	211.6 214.3	11.1	754
10"	250	330	406	19	273	268.3	12.7	890
12"	300	356	483	19	323.9	318.3	12.7	1031

300PSI NRS Flanged End Gate Valve Model: Z45-300

Resilient Wedge NRS Gate valve – Flanged End

Technical Features

- Nominal Pressure: 300PSI
- Flange Standard: ASME / ANSI B16.1 Class 125 or ASME / ANSI B16.42 Class 150 or BS EN1092-2 PN16 or GB / T9113.1
- Sizes: 2½", 3", 4", 5", 6", 8", 10", 12"
- Face to Face Standard: ASME B16.10
- Approvals: UL, CUL, FM, NSF / ANSI 61 & NSF / ANSI 372, CCC
- Maximum Working Pressure: 300PSI (Maximum Testing Pressure: 600PSI) conforms to UL262, ULC / ORD C262-92 , FM 1120 / 1130
- Maximum Working Temperature: 80°C / 176°F
- Coating Details: Epoxy coated interior and exterior by Electrostatic Spray or Coating upon request
- NPT plug on body with 2 operating nuts
- Certified lead-free by NSF / ANSI 61 & NSF / ANSI 372 is available

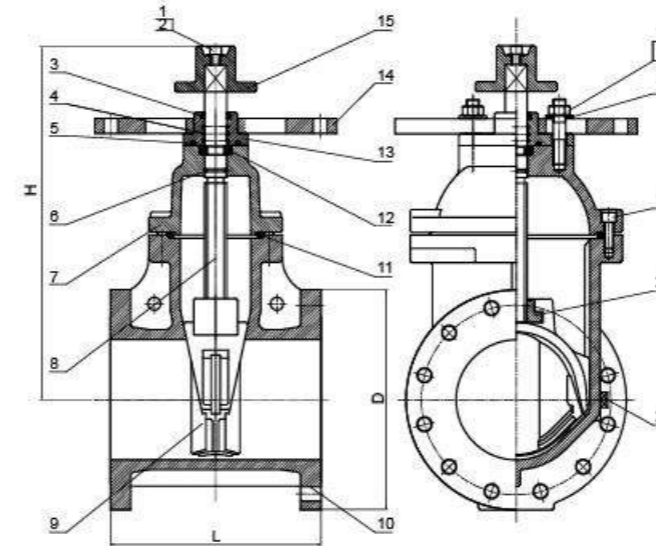

Dimensions

Size	DN	L	D	H
2½"	65	190	178	292
3"	80	203	191	322
4"	100	229	229	342
5"	125	254	254	412
6"	150	267	279	448
8"	200	292	343	534
10"	250	330	406	635
12"	300	356	483	720

Valve Material List

NO.	Name	Material
1	Flat Washer	Steel 1045 or Stainless Steel 304
2	Inner Hexagon Screw	Steel 1045 or Stainless Steel 304
3	Sealing Gland	EPDM
4	O-Ring	EPDM
5	Sealing Ring	EPDM
6	O-Ring	EPDM
7	Bonnet	Ductile Iron
8	Stem	Stainless Steel 304
9	Disc	Ductile Iron +EPDM
10	Body	Ductile Iron
11	Sealing Ring	EPDM
12	Retaining Ring	C95400
13	Gland	Ductile Iron
14	Terminal Pad	Ductile Iron
15	Link Block	Ductile Iron
16	Nut	Stainless Steel 304 or Steel 1045
17	Studs	Stainless Steel 304 or Steel 1045
18	Washer	Steel 1045
19	Inner Hexagon Screw	Steel 1045
20	Master Screw	C95400
21	Plug	C95400

300PSI NRS Grooved End Gate Valve

Model: Z85-300

Resilient Wedge NRS Gate valve – Grooved End

Technical Features

- Nominal Pressure: 300PSI
- Groove standard: Metric or ANSI / AWWA C606
- Face to Face Standard: ASME B16.10
- Sizes: 2½", 3", 4", 5", 6", 8", 10", 12"
- Approvals: UL, CUL, FM, NSF / ANSI 61 & NSF / ANSI 372
- Maximum Working Pressure: 300PSI (Maximum Testing Pressure: 600 PSI) conforms to UL262, ULC / ORD C262-92, FM 1120 / 1130
- Maximum Working Temperature: 80°C / 176°F
- Coating Details: Epoxy coated interior and exterior by Electrostatic Spray or Coating upon request
- NPT plug on body with 2 operating nuts
- Certified lead-free by NSF / ANSI 61 & NSF / ANSI 372 is available

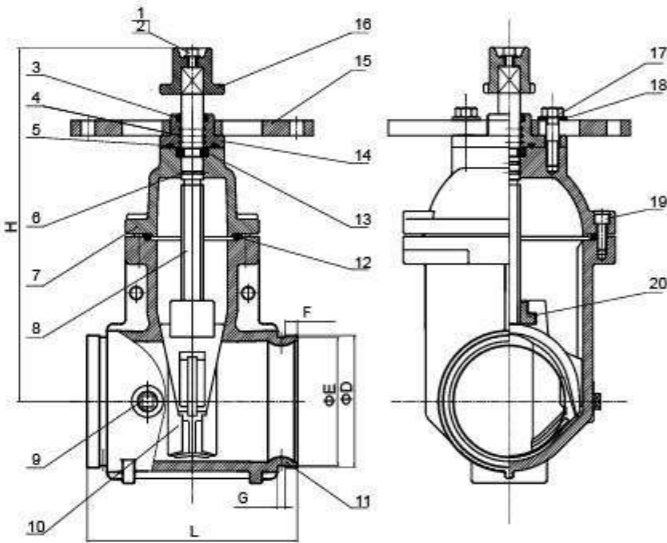

Dimensions

Size	DN	L	F	D	E	G	H
2½"	65	190	15.9	73 76.1	69.1 72.3	7.9	292
3"	80	203	15.9	88.9	84.9	7.9	322
4"	100	229	15.9	114.3	110.1	9.5	342
5"	125	254	15.9	139.7 141.3	135.5 137	9.5	412
6"	150	267	15.9	165.1 168.3	160.8 163.9	9.5	448
8"	200	292	19	216.3 219.1	211.6 214.3	11.1	534
10"	250	330	19	273	268.3	12.7	635
12"	300	356	19	323.9	318.3	12.7	720

Valve Material List

NO.	Name	Material
1	Flat Washer	Steel 1045 or Stainless Steel 304
2	Hexagon Socket Screw	Steel 1045 or Stainless Steel 304
3	Sealing Ring	EPDM
4	O-Ring	EPDM
5	Sealing Ring	EPDM
6	O-Ring	EPDM
7	Bonnet	Ductile Iron
8	Stem	Stainless Steel 304 or C95400
9	Plug	Stainless Steel 304 or C95400
10	Disc	Ductile Iron +EPDM
11	Body	Ductile Iron
12	Sealing Ring	EPDM
13	Retaining Ring	C95400
14	Gland	Ductile Iron
15	Post Flange	Ductile Iron
16	Wrench Nut	Ductile Iron
17	Bolt	Stainless Steel 304 or Steel 1045
18	Washer	Stainless Steel 304 or Steel 1045
19	Hexagon Socket Screw	Steel 1045 or Stainless Steel 304
20	Stem Nut	CF8 or C95400

300PSI NRS Flanged x Grooved End Gate Valve

Model: Z485-300

Resilient Wedge NRS Gate valve – Grooved x Flanged End

Technical Features

- Nominal Pressure: 300PSI
- Face to Face Standard: ASME B16.10
- Sizes: 2½", 3", 4", 5", 6", 8", 10", 12"
- Flange Standard: ASME / ANSI B16.1 Class 125 or ASME / ANSI B16.42 Class 150 or BS EN1092-2 PN16 or GB / T9113.1
- Groove Standard: Metric or ANSI / AWWA C606
- Approvals: UL, CUL, FM, NSF / ANSI 61 & NSF / ANSI 372
- Maximum Working Pressure: 300PSI (Maximum Testing Pressure: 600 PSI) conforms to UL262, ULC / ORD C262-92, FM 1120 / 1130
- Maximum Working Temperature: 80°C / 176°F
- Coating Details: Epoxy coated interior and exterior by Electrostatic Spray or Coating upon request
- NPT plug on body with 2 operating nuts
- Certified lead-free by NSF / ANSI 61 & NSF / ANSI 372 is available

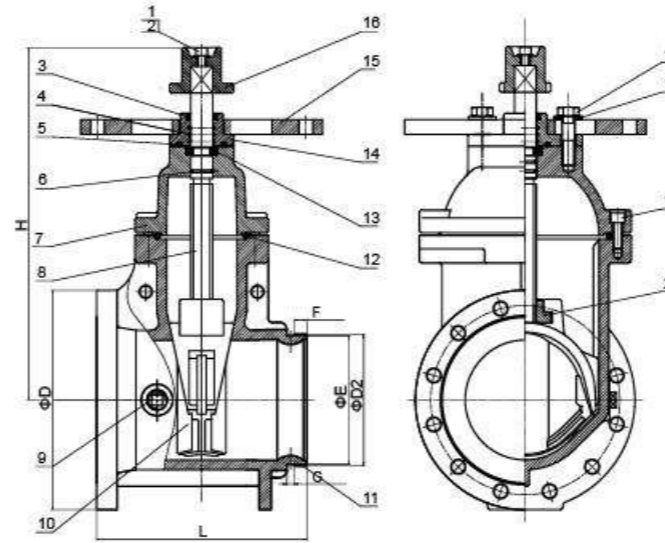

Dimensions

Size	DN	L	D	F	D2	E	G	H
2½"	65	190	178	15.9	73 76.1	69.1 72.3	7.9	292
3"	80	203	191	15.9	88.9	84.9	7.9	322
4"	100	229	229	15.9	114.3	110.1	9.5	342
5"	125	254	254	15.9	139.7 141.3	135.5 137	9.5	412
6"	150	267	279	15.9	165.1 168.3	160.8 163.9	9.5	448
8"	200	292	343	19	216.3 219.1	211.6 214.3	11.1	534
10"	250	330	406	19	273	268.3	12.7	635
12"	300	356	483	19	323.9	318.3	12.7	720

Valve Material List

NO.	Name	Material
1	Flat Washer	Steel 1045 or Stainless Steel 304
2	Hexagon Socket Screw	Steel 1045 or Stainless Steel 304
3	Sealing Ring	EPDM
4	O-Ring	EPDM
5	Sealing Ring	EPDM
6	O-Ring	EPDM
7	Bonnet	Ductile Iron
8	Stem	Stainless Steel 304 or C95400
9	Plug	Stainless Steel 304 or C95400
10	Disc	Ductile Iron +EPDM
11	Body	Ductile Iron
12	Sealing Ring	EPDM
13	Retaining Ring	C95400
14	Gland	Ductile Iron
15	Post Flange	Ductile Iron
16	Wrench Nut	Ductile Iron
17	Bolt	Stainless Steel 304 or Steel 1045
18	Washer	Stainless Steel 304 or Steel 1045
19	Hexagon Socket Screw	Steel 1045 or Stainless Steel 304
20	Stem Nut	CF8 or C95400

300PSI OS&Y Flanged End Gate Valve

Model: Z41-300A

Resilient Wedge OS & Y Gate Valve – Flanged End

Technical Features

- Nominal Pressure: 300PSI
- Conforms: ANSI / AWWA C515 Standard
- Face to Face Standard : ASME B16.10
- Sizes: 2½", 3", 4", 5", 6", 8", 10", 12"
- Flange Standard: ASME / ANSI B16.1 Class 125 or ASME / ANSI B16.42 Class 150 or BS EN1092-2 PN16 or GB / T9113.1
- Approvals: FM, UL, CUL, NSF / ANSI 61 & NSF / ANSI 372
- Maximum Working Pressure: 300PSI (Maximum Testing Pressure: 600 PSI) conforms to UL262, ULC / ORD C262-92 , FM 1120 / 1130
- Maximum Working Temperature: 80°C / 176°F
- Coating Details: Epoxy coated interior and exterior by Electrostatic Spray or Coating upon request
- NPT plug on body with 2 operating nuts
- Certified lead-free by NSF/ANSI 61 & NSF / ANSI 372 is available

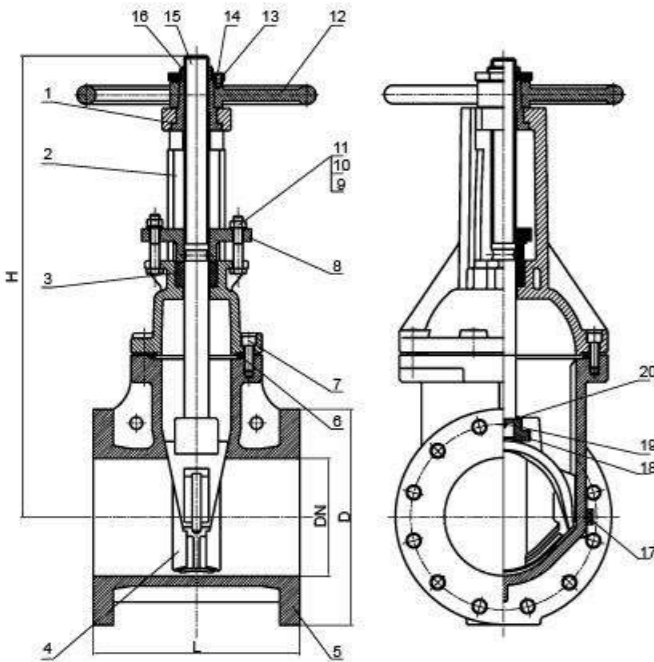

Dimensions

Size	DN	L	D	H
2½"	65	190	178	370
3"	80	203	191	420
4"	100	229	229	447
5"	125	254	254	547
6"	150	267	279	607
8"	200	292	343	754
10"	250	330	406	890
12"	300	356	483	1031

Valve Material List

NO.	Name	Material
1	Gasket	Stainless Steel 304 or C95400
2	Bonnet	Ductile Iron
3	Packing	Graphite
4	Disc	Ductile Iron +EPDM
5	Body	Ductile Iron
6	Sealing Ring	EPDM
7	Bolt	Stainless Steel 304 or Steel 1045
8	Gland	Ductile Iron
9	Nut	Stainless Steel 304 or Steel 1045
10	Flat Washer	Stainless Steel 304 or Steel 1045
11	Bolt	Stainless Steel 304 or Steel 1045
12	Handwheel	Ductile Iron
13	Lock Nut	C95400
14	Locating Screw	Stainless Steel 304 or Steel 1045
15	Stem	Stainless Steel 304 or C95400
16	Stem Nut	C95400
17	Plug	C95400
18	Lifting Nut	CF8 or C95400
19	Pin	Stainless Steel 304
20	Sealing Ring	EPDM

300PSI OS&Y Grooved End Gate Valve

Model: Z81-300A

Resilient Wedge OS & Y Gate Valve – Grooved End

Technical Features

- Nominal Pressure: 300PSI
- Conforms: ANSI / AWWA C515 Standard
- Groove Standard: ANSI / AWWA C606 or Metric
- Face to Face Standard: ASME B16.10
- Sizes: 2½", 3", 4", 5", 6", 8", 10", 12"
- Approvals: FM, UL, CUL, NSF / ANSI 61 & NSF / ANSI 372
- Maximum Working Pressure: 300PSI (Maximum Testing Pressure: 600 PSI) conforms to UL262, ULC / ORD C262-92 , FM 1120 / 1130
- Maximum Working Temperature: 80°C / 176°F
- Coating Details: Epoxy coated interior and exterior by Electrostatic Spray or Coating upon request
- NPT plug on body with 2 operating nuts
- Certified lead-free by NSF / ANSI 61 & NSF / ANSI 372 is available

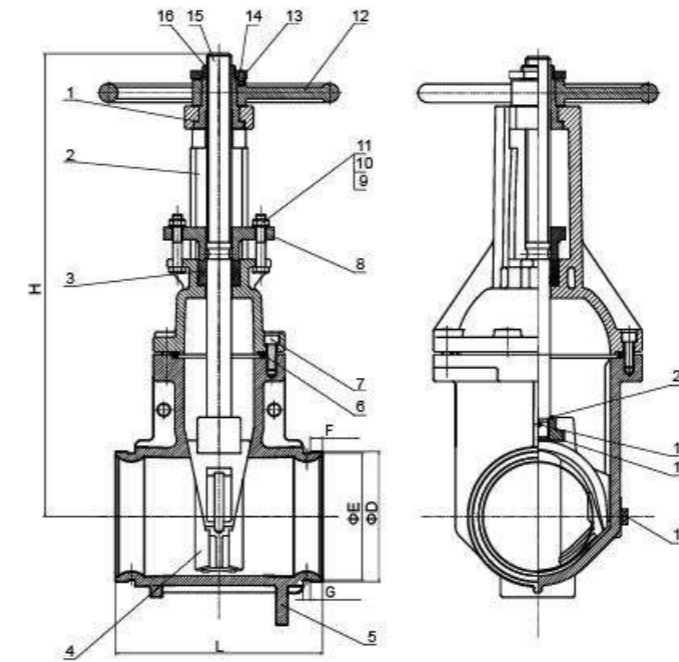

Dimensions

Size	DN	L	F	D	E	G	H
2½"	65	190	15.9	73	69.1	7.9	370
3"	80	203	15.9	88.9	84.9	7.9	420
4"	100	229	15.9	114.3	110.1	9.5	447
5"	125	254	15.9	139.7	135.5	9.5	547
6"	150	267	15.9	165.1	160.8	9.5	607
8"	200	292	19	216.3	211.6	11.1	754
10"	250	330	19	273	268.3	12.7	890
12"	300	356	19	323.9	318.3	12.7	1031

Valve Material List

NO.	Name	Material
1	Gasket	Stainless Steel 304 or C95400
2	Bonnet	Ductile Iron
3	Packing	Graphite
4	Disc	Ductile Iron +EPDM
5	Body	Ductile Iron
6	Sealing Ring	EPDM
7	Bolt	Stainless Steel 304 or Steel 1045
8	Gland	Ductile Iron
9	Nut	Stainless Steel 304 or Steel 1045
10	Flat Washer	Stainless Steel 304 or Steel 1045
11	Bolt	Stainless Steel 304 or Steel 1045
12	Handwheel	Ductile Iron
13	Lock Nut	C95400
14	Locating Screw	Stainless Steel 304 or Steel 1045
15	Stem	Stainless Steel 304 or C95400
16	Stem Nut	C95400
17	Plug	C95400
18	Lifting Nut	CF8 or C95400
19	Pin	Stainless Steel 304
20	Sealing Ring	EPDM

300PSI OS&Y Flanged X Grooved End Gate Valve

Model: Z481-300A

Resilient Wedge OS & Y Gate Valve – Flanged x Grooved End

Technical Features

- Nominal Pressure: 300PSI
- Conforms: ANSI / AWWA C515 Standard
- Face to Face Standard : ASME B16.10
- Sizes: 2½", 3", 4", 5", 6", 8", 10", 12"
- Flange Standard: ASME / ANSI B16.1 Class 125 or ASME / ANSI B16.42 Class 150 or BS EN1092-2 PN16 or GB / T9113.1
- Groove Standard: ANSI / AWWA C606 or Metric
- Approvals: FM, UL, CUL, NSF / ANSI 61 & NSF/ANSI 372
- Maximum Working Pressure: 300PSI (Maximum Testing Pressure: 600 PSI) conforms to UL262, ULC / ORD C262-92 , FM 1120 / 1130
- Maximum Working Temperature: 80°C / 176°F
- Coating Details: Epoxy coated interior and exterior by Electrostatic Spray or Coating upon request
- NPT plug on body with 2 operating nuts
- Certified lead-free by NSF / ANSI 61 & NSF / ANSI 372 is available

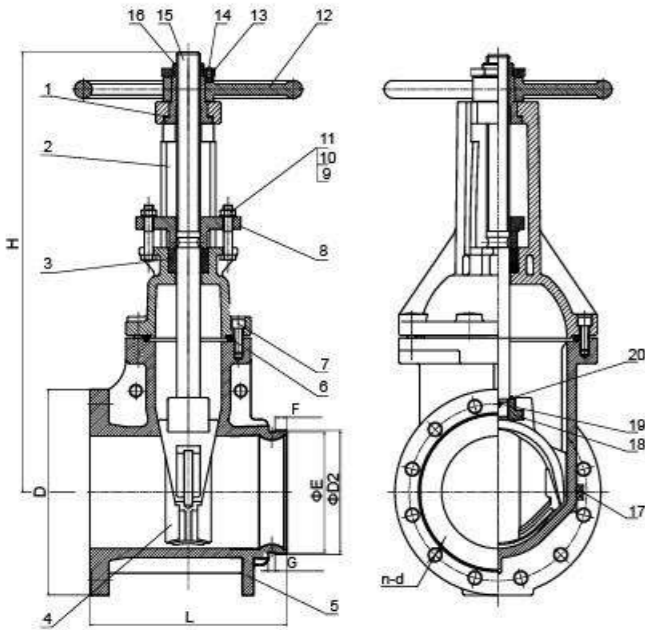

Dimensions

Size	DN	L	D	F	D2	E	G	H
2½"	65	190	178	15.9	73 76.1	69.1 72.3	7.9	370
3"	80	203	191	15.9	88.9	84.9	7.9	420
4"	100	229	229	15.9	114.3	110.1	9.5	447
5"	125	254	254	15.9	139.7 141.3	135.5 137	9.5	547
6"	150	267	279	15.9	165.1 168.3	160.8 163.9	9.5	607
8"	200	292	343	19	216.3 219.1	211.6 214.3	11.1	754
10"	250	330	406	19	273	268.3	12.7	890
12"	300	356	483	19	323.9	318.3	12.7	1031

Valve Material List

NO.	Name	Material
1	Gasket	Stainless Steel 304 or C95400
2	Bonnet	Ductile Iron
3	Packing	Graphite
4	Disc	Ductile Iron +EPDM
5	Body	Ductile Iron
6	Sealing Ring	EPDM
7	Bolt	Stainless Steel 304 or Steel 1045
8	Gland	Ductile Iron
9	Nut	Stainless Steel 304 or Steel 1045
10	Flat Washer	Stainless Steel 304 or Steel 1045
11	Bolt	Stainless Steel 304 or Steel 1045
12	Handwheel	Ductile Iron
13	Lock Nut	C95400
14	Locating Screw	Stainless Steel 304 or Steel 1045
15	Stem	Stainless Steel 304 or C95400
16	Stem Nut	C95400
17	Plug	C95400
18	Lifting Nut	CF8 or C95400
19	Pin	Stainless Steel 304
20	Sealing Ring	EPDM

300PSI NRS Flanged End Gate Valve

Model: Z45-300A

Resilient Wedge NRS Gate Valve – Flanged End

Technical Features

- Nominal Pressure: 300PSI
- Conforms: ANSI / AWWA C515 Standard
- Face to Face Standard : ASME B16.10
- Sizes: 2", 2½", 3", 4", 5", 6", 8", 10", 12"
- 2" FM only
- Flange Standard: ASME / ANSI B16.1 Class 125 or ASME / ANSI B16.42 Class 150 or BS EN1092-2 PN16 or GB / T9113.1
- Approvals: FM, UL, CUL, NSF / ANSI 61 & NSF / ANSI 372
- Maximum Working Pressure: 300PSI (Maximum Testing Pressure: 600 PSI) conforms to UL262, ULC / ORD C262-92 , FM 1120 / 1130
- Maximum Working Temperature: 80°C / 176°F
- Coating Details: Epoxy coated interior and exterior by Electrostatic Spray or Coating upon request
- NPT plug on body with 2 operating nuts
- Certified lead-free by NSF / ANSI 61 & NSF / ANSI 372 is available
- With and Without Post Flange are available

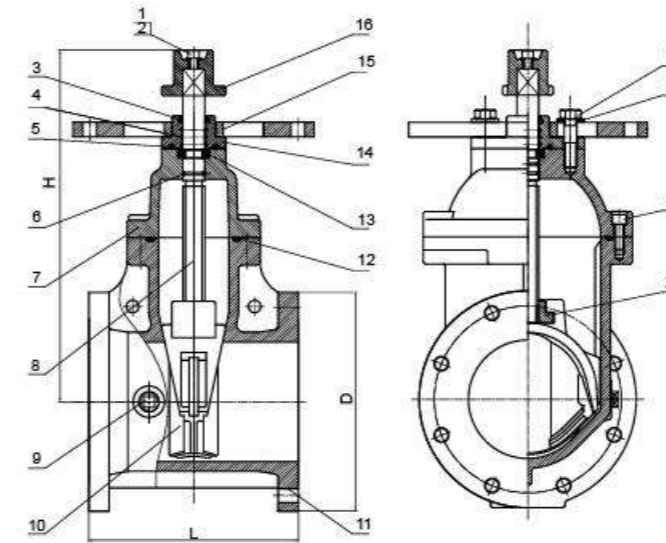

Dimensions

Size	DN	L	D	H
2"	50	178	152	265
2½"	65	190	178	292
3"	80	203	191	322
4"	100	229	229	342
5"	125	254	254	412
6"	150	267	279	448
8"	200	292	343	534
10"	250	330	406	635
12"	300	356	483	720

Valve Material List

NO.	Name	Material
1	Flat Washer	Steel 1045 or Stainless Steel 304
2	Hexagon Socket Screw	Steel 1045 or Stainless Steel 304
3	Sealing Ring	EPDM
4	O-ring	EPDM
5	Sealing Ring	EPDM
6	O-ring	EPDM
7	Bonnet	Ductile Iron
8	Stem	Stainless Steel 304 or Steel 1045
9	Plug	Stainless Steel 304 or Steel 1045
10	Disc	Ductile Iron +EPDM
11	Body	Ductile Iron
12	Sealing Ring	EPDM
13	Retaining Ring	C95400
14	Gland	Ductile Iron
15	Post Flange	Ductile Iron
16	Wrench Nut	Ductile Iron
17	Bolt	Stainless Steel 304 or Steel 1045
18	Washer	Stainless Steel 304 or Steel 1045
19	Hexagon Socket Screw	Steel 1045 or Stainless Steel 304
20	Stem Nut	CF8 or C95400

300PSI NRS Grooved End Gate Valve

Model: Z85-300A

Resilient Wedge NRS Gate Valve – Grooved End

Technical Features

- Nominal Pressure: 300PSI
- Conforms: ANSI / AWWA C515 Standard
- Groove Standard: ANSI / AWWA C606 or Metric
- Face to Face Standard: ASME B16.10
- Sizes: 2½", 3", 4", 5", 6", 8", 10", 12"
- Approvals: FM, UL, CUL, NSF / ANSI 61 & NSF / ANSI 372
- Maximum Working Pressure: 300PSI (Maximum Testing Pressure: 600 PSI) conforms to UL262, ULC/ORD C262-92, FM 1120 / 1130
- Maximum Working Temperature: 80°C / 176°F
- Coating Details: Epoxy coated interior and exterior by Electrostatic Spray or Coating upon request
- NPT plug on body with 2 operating nuts
- Certified lead-free by NSF / ANSI 61 & NSF / ANSI 372 is available
- With and Without Post Flange are available

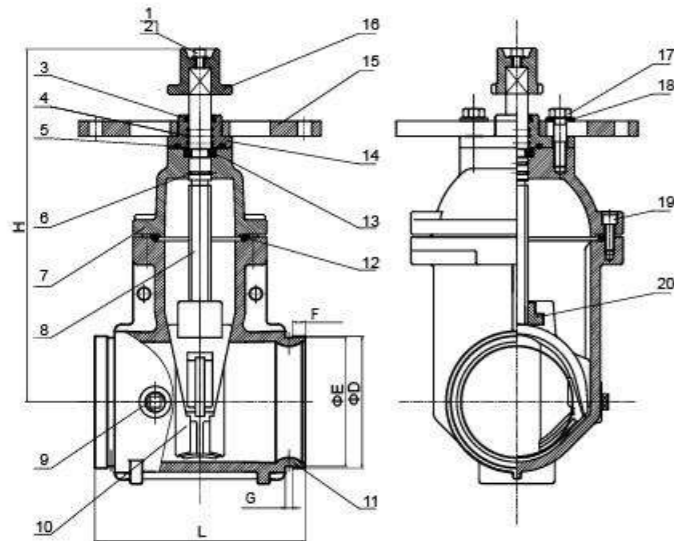

Dimensions

Size	DN	L	F	D	E	G	H
2½"	65	190	15.9	73 76.1	69.1 72.3	7.9	292
3"	80	203	15.9	88.9	84.9	7.9	322
4"	100	229	15.9	114.3	110.1	9.5	342
5"	125	254	15.9	139.7 141.3	135.5 137	9.5	412
6"	150	267	15.9	165.1 168.3	160.8 163.9	9.5	448
8"	200	292	19	216.3 219.1	211.6 214.3	11.1	534
10"	250	330	19	273	268.3	12.7	635
12"	300	356	19	323.9	318.3	12.7	720

Valve Material List

NO.	Name	Material
1	Flat Washer	Steel 1045 or Stainless Steel 304
2	Hexagon Socket Screw	Steel 1045 or Stainless Steel 304
3	Sealing Ring	EPDM
4	O-ring	EPDM
5	Sealing Ring	EPDM
6	O-ring	EPDM
7	Bonnet	Ductile Iron
8	Stem	Stainless Steel 304 or Steel 1045
9	Plug	Stainless Steel 304 or Steel 1045
10	Disc	Ductile Iron +EPDM
11	Body	Ductile Iron
12	Sealing Ring	EPDM
13	Retaining Ring	C95400
14	Gland	Ductile Iron
15	Post Flange	Ductile Iron
16	Wrench Nut	Ductile Iron
17	Bolt	Stainless Steel 304 or Steel 1045
18	Washer	Stainless Steel 304 or Steel 1045
19	Hexagon Socket Screw	Steel 1045 or Stainless Steel 304
20	Stem Nut	CF8 or C95400

300PSI NRS Flanged X Grooved End Gate Valve

Model: Z485-300A

Resilient Wedge NRS Gate Valve – Flanged x Grooved End

Technical Features

- Nominal Pressure: 300PSI
- Conforms: ANSI / AWWA C515 Standard
- Flange Standard: ASME / ANSI B16.1 Class 125 or ASME / ANSI B16.42 Class 150 or BS EN1092-2 PN16 or GB / T9113.1
- Groove Standard: ANSI / AWWA C606 or Metric
- Face to Face Standard: ASME B16.10
- Sizes: 2½", 3", 4", 5", 6", 8", 10", 12"
- Approvals: FM, UL, CUL, NSF / ANSI 61 & NSF/ANSI 372
- Maximum Working Pressure: 300PSI (Maximum Testing Pressure: 600 PSI) conforms to UL262, ULC / ORD C262-92, FM 1120 / 1130
- Maximum Working Temperature: 80°C / 176°F
- Coating Details: Epoxy coated interior and exterior by Electrostatic Spray or Coating upon request
- NPT plug on body with 2 operating nuts
- Certified lead-free by NSF / ANSI 61 & NSF / ANSI 372 is available
- With and Without Post Flange are available

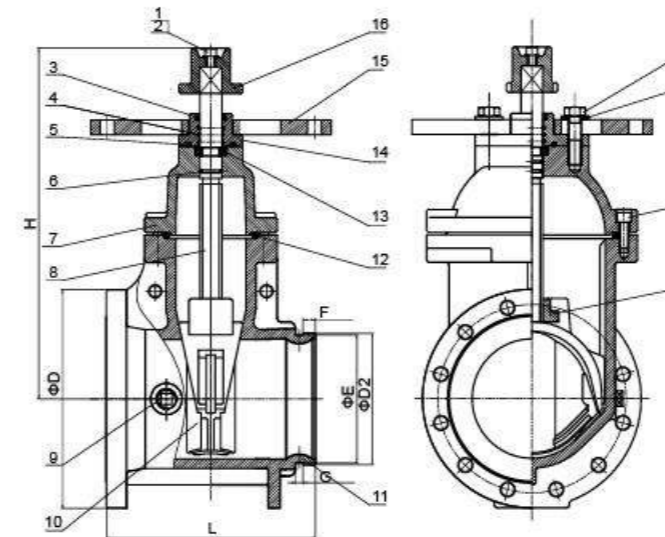

Dimensions

Size	DN	L	D	F	D2	E	G	H
2½"	65	190	178	15.9	73 76.1	69.1 72.3	7.9	292
3"	80	203	191	15.9	88.9	84.9	7.9	322
4"	100	229	229	15.9	114.3	110.1	9.5	342
5"	125	254	254	15.9	139.7 141.3	135.5 137	9.5	412
6"	150	267	279	15.9	165.1 168.3	160.8 163.9	9.5	448
8"	200	292	343	19	216.3 219.1	211.6 214.3	11.1	534
10"	250	330	406	19	273	268.3	12.7	635
12"	300	356	483	19	323.9	318.3	12.7	720

Valve Material List

NO.	Name	Material
1	Flat Washer	Steel 1045 or Stainless Steel 304
2	Hexagon Socket Screw	Steel 1045 or Stainless Steel 304
3	Sealing Ring	EPDM
4	O-Ring	EPDM
5	Sealing Ring	EPDM
6	O-Ring	EPDM
7	Bonnet	Ductile Iron
8	Stem	Stainless Steel 304 or Steel 1045
9	Plug	Stainless Steel 304 or Steel 1045
10	Disc	Ductile Iron +EPDM
11	Body	Ductile Iron
12	Sealing Ring	EPDM
13	Retaining Ring	C95400
14	Gland	Ductile Iron
15	Post Flange	Ductile Iron
16	Wrench Nut	Ductile Iron
17	Bolt	Stainless Steel 304 or Steel 1045
18	Washer	Stainless Steel 304 or Steel 1045
19	Hexagon Socket Screw	Steel 1045 or Stainless Steel 304
20	Stem Nut	CF8 or C95400

300PSI NRS FL X MJ Gate Valve

Model: Z45-300FJA

Resilient Wedge NRS Gate Valve – Flanged x Mechanical Joint End

Technical Features

- Nominal Pressure: 300PSI
- Conforms: ANSI / AWWA C515 Standard
- Sizes: 2", 3", 4", 6", 8", 10", 12"
- 2" FM only
- Flange Standard: ASME / ANSI B16.1 Class 125 or ASME / ANSI B16.42 Class 150 or BS EN1092-2 PN16 or GB / T9113.1
- Mechanical Standard : ANSI / AWWA 110 or ANSI / AWWA C153
- Approvals: FM, UL, CUL, NSF / ANSI 61 & NSF / ANSI 372
- Maximum Working Pressure: 300PSI (Maximum Testing Pressure: 600 PSI) conforms to UL262, ULC / ORD C262-92 , FM 1120 / 1130
- Maximum Working Temperature: 80°C / 176°F
- Coating Details: Epoxy coated interior and exterior by Electrostatic Spray or Coating upon request
- NPT plug on body with 1 operating nut
- Certified lead-free by NSF/ANSI 61 & NSF / ANSI 372 is available.
- With and Without Post Flange are available

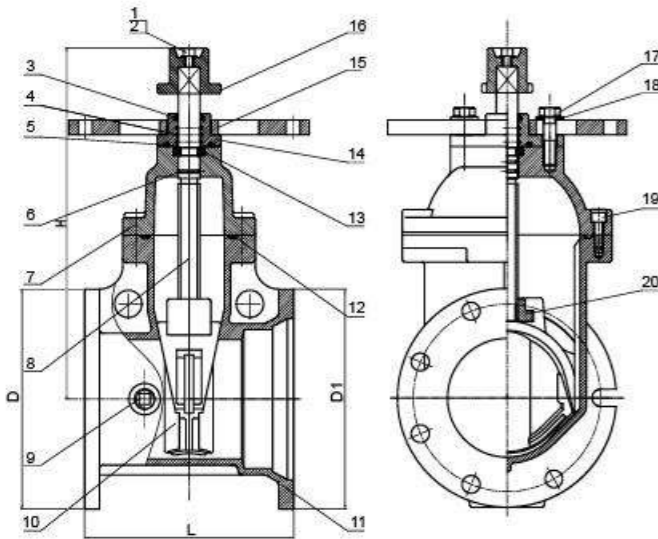

Dimensions

Size	DN	L	D	D1	H
2"	50	178	152	152	265
3"	80	203	191	195	322
4"	100	229	229	232	342
6"	150	267	279	282	448
8"	200	292	343	340	534
10"	250	330	406	399	635
12"	300	356	483	456	720

Valve Material List

NO.	Name	Material
1	Flat Washer	Steel 1045 or Stainless Steel 304
2	Hexagon Socket Screw	Steel 1045 or Stainless Steel 304
3	Sealing Ring	EPDM
4	O-Ring	EPDM
5	Sealing Ring	EPDM
6	O-Ring	EPDM
7	Bonnet	Ductile Iron
8	Stem	Stainless Steel 304 or Steel 1045
9	Plug	Stainless Steel 304 or Steel 1045
10	Disc	Ductile Iron +EPDM
11	Body	Ductile Iron
12	Sealing Ring	EPDM
13	Retaining Ring	C95400
14	Gland	Ductile Iron
15	Post Flange	Ductile Iron
16	Wrench Nut	Ductile Iron
17	Bolt	Stainless Steel 304 or Steel 1045
18	Washer	Stainless Steel 304 or Steel 1045
19	Hexagon Socket Screw	Steel 1045 or Stainless Steel 304
20	Stem Nut	CF8 or C95400

300PSI NRS MJ X MJ Gate Valve

Model: Z45-300MJA

Resilient Wedge NRS Gate Valve – Mechanical Joint x Mechanical Joint End

Technical Features

- Nominal Pressure: 300PSI
- Conforms: ANSI / AWWA C515 Standard
- Sizes: 2", 3", 4", 6", 8", 10", 12"
- 2" FM only
- Mechanical Standard : ANSI / AWWA 110 or ANSI / AWWA C153
- Approvals: FM, UL, CUL, NSF / ANSI 61 & NSF / ANSI 372
- Maximum Working Pressure: 300PSI (Maximum Testing Pressure: 600 PSI) conforms to UL262, ULC/ORD C262-92 , FM 1120 / 1130
- Maximum Working Temperature: 80°C / 176°F
- Coating Details:Epoxy coated interior and exterior by Electrostatic Spray or Coating upon request
- Certified lead-free by NSF / ANSI 61 & NSF / ANSI 372 is available
- With and Without Post Flange are available

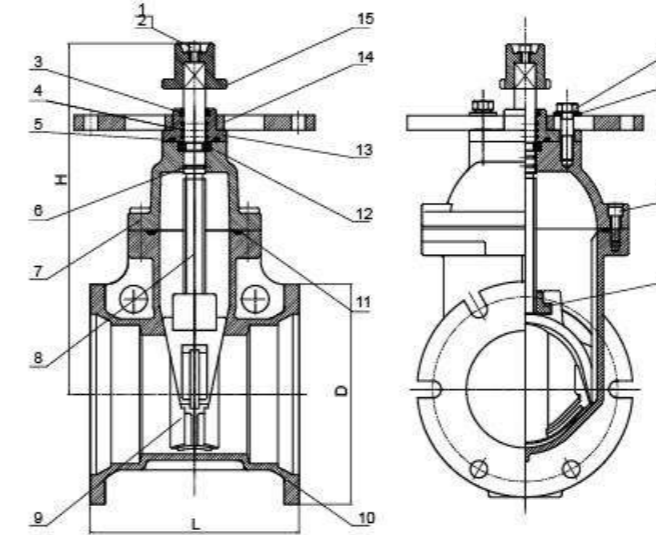

Dimensions

Size	DN	L	D	H
2"	50	178	152	265
3"	80	203	195	322
4"	100	229	232	342
6"	150	267	282	448
8"	200	292	340	534
10"	250	330	399	635
12"	300	356	456	720

Valve Material List

NO.	Name	Material
1	Flat Washer	Steel 1045 or Stainless Steel 304
2	Hexagon Socket Screw	Steel 1045 or Stainless Steel 304
3	Sealing Ring	EPDM
4	O-Ring	EPDM
5	Sealing Ring	EPDM
6	O-Ring	EPDM
7	Bonnet	Ductile Iron
8	Stem	Stainless Steel 304 or Steel 1045
9	Plug	Stainless Steel 304 or Steel 1045
10	Disc	Ductile Iron +EPDM
11	Body	Ductile Iron
12	Sealing Ring	EPDM
13	Retaining Ring	C95400
14	Gland	Ductile Iron
15	Post Flange	Ductile Iron
16	Wrench Nut	Ductile Iron
17	Bolt	Stainless Steel 304 or Steel 1045
18	Washer	Stainless Steel 304 or Steel 1045
19	Hexagon Socket Screw	Steel 1045 or Stainless Steel 304
20	Stem Nut	CF8 or C95400

200PSI OS&Y Flanged End Gate Valve

Model: Z41

Resilient Wedge OS&Y Gate Valve – Flanged End

Technical Features

- Nominal Pressure: 200PSI
- Flange Standard: ASME / ANSI B16.1 Class 125 or ASME / ANSI B16.42 Class 150 or BS EN1092-2 PN16 or GB / T9113.1
- Face to Face Standard: ASME B16.10
- Sizes: 2", 2½", 3", 4", 5", 6", 8", 10", 12" with FM UL CUL
- 14", 16" with FM only
- Approvals: FM, UL, CUL, NSF / ANSI 61 & NSF / ANSI 372
- Maximum Working Pressure: 200PSI (Maximum Testing Pressure: 400 PSI) conforms to UL 262, ULC / ORD C262-92, FM 1120 / 1130
- Maximum Working Temperature: 80°C / 176°F
- Coating Details: Epoxy coated interior and exterior by Electrostatic Spray or Coating upon request
- NPT plug on body with 2 operating nuts
- Certified lead-free by NSF / ANSI 61 & NSF / ANSI 372 is available



Valve Material List

NO.	Name	Material
1	Body	Ductile Iron
2	Disc	Ductile Iron +EPDM
3	Connecting Part	C95400
4	Sealing Pad	EPDM
5	Stem	Stainless Steel 304
6	Yoke	Ductile Iron
7	Bolt	Steel 1045
8	Gland	Ductile Iron
9	Nut	Steel 1045
10	Rotating Nut	C95400
11	Handwheel	Steel 1045
12	Lock Nut	Steel 1045
13	Countersunk Head Bolt	Steel 1045
14	Cylinder Pin	Stainless Steel 304

Dimensions

Size	L	H	øD
2"	178	313	152
2½"	190	340	178
3"	203	387	191
4"	229	440	229
5"	254	546	254
6"	267	607	279
8"	292	786	343
10"	330	946	406
12"	356	1110	483

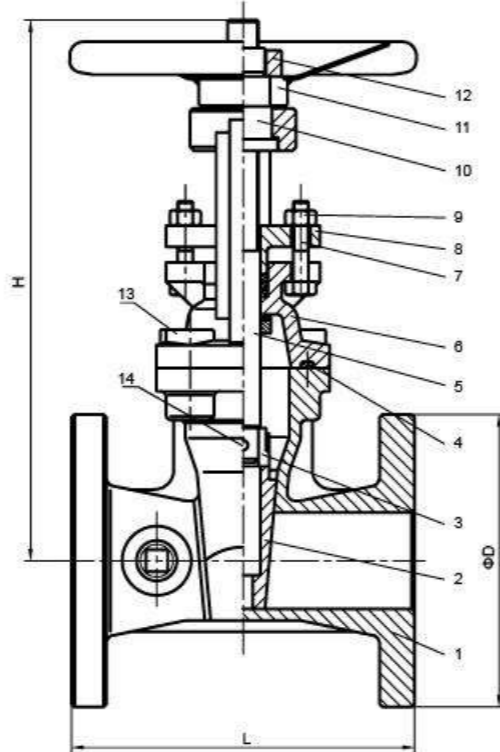

200PSI OS&Y Flanged x Grooved End Gate Valve

Model: Z481

Resilient Wedge OS&Y Gate Valve – Flanged x Grooved End

Technical Features

- Nominal Pressure: 200PSI
- Flange Standard: ASME / ANSI B16.1 Class 125 or ASME / ANSI B16.42 Class 150 or BS EN1092-2 PN16 or GB / T9113.1
- Groove standard : ANSI / AWWA C606 or Metric
- Face to Face Standard: ASME B16.10
- Sizes: 2", 2½", 3", 4", 5", 6", 8", 10", 12"
- Approvals: FM, UL, CUL, NSF / ANSI 61 & NSF / ANSI 372
- Maximum Working Pressure: 200 PSI (Maximum Testing Pressure: 400 PSI) conforms to UL 262, ULC / ORD C262-92, FM 1120 / 1130
- Maximum Working Temperature: 80°C / 176°F
- Coating Details: Epoxy coated interior and exterior by Electrostatic Spray or Coating upon request
- NPT plug on body with 2 operating nuts
- Certified lead-free by NSF / ANSI 61 & NSF / ANSI 372 is available



Valve Material List

NO.	Name	Material
1	Body	Ductile Iron
2	Disc	Ductile Iron +EPDM
3	Connecting Part	C95400
4	Sealing Pad	EPDM
5	Stem	Stainless Steel 304
6	Yoke	Ductile Iron
7	Bolt	Steel 1045
8	Gland	Ductile Iron
9	Nut	Steel 1045
10	Rotating Nut	C95400
11	Handwheel	Steel 1045
12	Lock Nut	Steel 1045
13	Countersunk Head Bolt	Steel 1045
14	Cylinder Pin	Stainless Steel 304

Dimensions

Size	L	H	øD	øD1	øE	F	G
2"	178	313	152	60.3	57.2	15.9	7.9
2½"	190	340	178	76.1	72.3	15.9	7.9
3"	203	387	191	88.9	84.9	15.9	7.9
4"	229	440	229	114.3	110.1	15.9	9.5
5"	254	546	254	141.3	137	15.9	9.5
6"	267	607	279	168.3	163.9	15.9	9.5
8"	292	786	343	219.1	214.4	19	11.1
10"	330	946	406	273	268.3	19	12.7
12"	356	1110	483	323.9	318.3	19	12.7

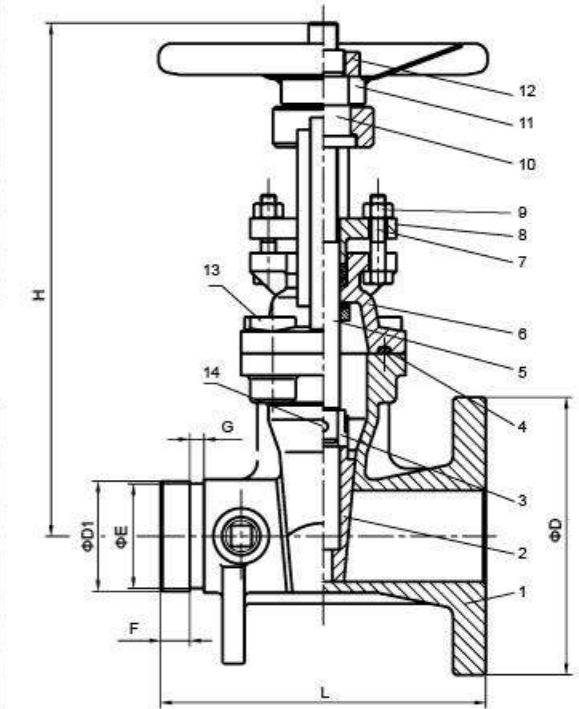

200PSI OS&Y Grooved End Gate Valve

Model: Z81

Resilient Wedge OS&Y Gate Valve – Grooved End

Technical Features

- Nominal Pressure: 200PSI
- Groove Standard : ANSI / AWWA C606 or Metric
- Face to Face Standard: ASME B16.10
- Sizes: 2", 2½", 3", 4", 5", 6", 8", 10", 12"
- Approvals: FM,UL, CUL, NSF / ANSI 61 & NSF / ANSI 372
- Maximum Working Pressure: 200PSI (Maximum Testing Pressure: 400 PSI) conforms to UL 262, ULC / ORD C262-92 , FM 1120 / 1130
- Maximum Working Temperature: 80°C / 176°F
- Coating Details: Epoxy coated interior and exterior by Electrostatic Spray or Coating upon request
- NPT plug on body with 2 operating nuts
- Certified lead-free by NSF / ANSI 61 & NSF / ANSI 372 is available



Valve Material List

NO.	Name	Material
1	Body	Ductile Iron
2	Disc	Ductile Iron +EPDM
3	Connecting Part	C95400
4	Sealing Pad	EPDM
5	Stem	Stainless Steel 304
6	Yoke	Ductile Iron
7	Bolt	Steel 1045
8	Gland	Ductile Iron
9	Nut	Steel 1045
10	Rotating Nut	C95400
11	Handwheel	Steel 1045
12	Lock Nut	Steel 1045
13	Countersunk Head Bolt	Steel 1045
14	Cylinder Pin	Stainless Steel 304

Dimensions

Size	L	H	øD	øE	F	G
2"	178	313	60.3	57.2	15.9	7.9
2½"	190	340	76.1	72.3	15.9	7.9
3"	203	387	88.9	84.9	15.9	7.9
4"	229	440	114.3	110.1	15.9	9.5
5"	254	546	141.3	137	15.9	9.5
6"	267	607	168.3	163.9	15.9	9.5
8"	292	786	219.1	214.4	19	11.1
10"	330	946	273	268.3	19	12.7
12"	356	1110	323.9	318.3	19	12.7

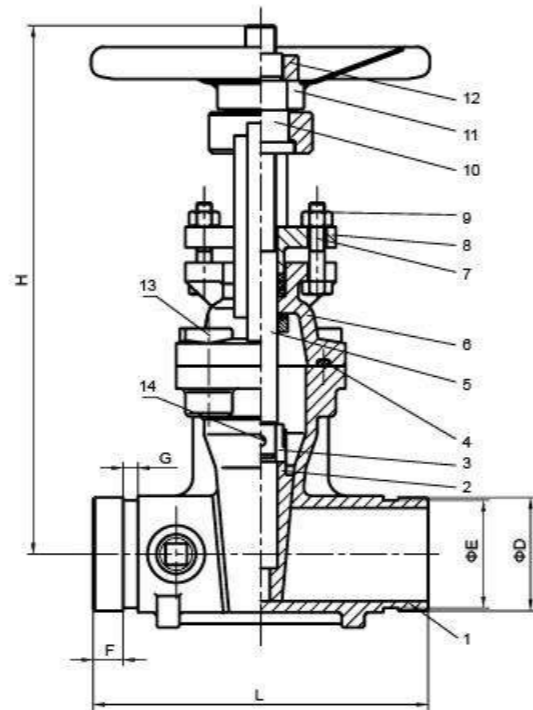

200PSI NRS Flanged End Gate Valve

Model: Z45

Resilient Wedge NRS Gate Valve – Flanged End

Technical Features

- Nominal Pressure: 200PSI
- Flange Standard: ASME / ANSI B16.1 Class 125 or ASME / ANSI B16.42 Class 150 or BS EN1092-2 PN16 or GB / T9113.1
- Face to Face Standard: ASME B16.10
- Sizes: 2", 2½", 3", 4", 5", 6", 8", 10", 12"
- Approvals: FM, UL, CUL, NSF / ANSI 61 & NSF / ANSI 372
- 2" without UL , CUL
- Maximum Working Pressure: 200PSI (Maximum Testing Pressure: 400 PSI) conforms to UL 262, ULC / ORD C262-92 , FM 1120 / 1130
- Maximum Working Temperature: 80°C / 176°F
- Coating Details: Epoxy coated interior and exterior by Electrostatic Spray or Coating upon request
- NPT plug on body with 2 operating nuts
- Certified lead-free by NSF / ANSI 61 & NSF / ANSI 372 is available



Valve Material List

NO.	Name	Material
1	Body	Ductile Iron
2	Disc	Ductile Iron+EPDM
3	Nut	C95400
4	Gasket	EPDM
5	Stem	Stainless Steel 304
6	Cap	Ductile Iron
7	Retainer Ring	C95400
8	O-ring	EPDM
9	Wrench Nut	Ductile Iron
10	Minipad	Steel 1045
11	Bolt	Steel 1045
12	Stud	Steel 1045
13	Nut	Steel 1045
14	Flat Washer	Steel 1045
15	Coupling Flange	Ductile Iron
16	Platen	Ductile Iron
17	Countersunk Head Bolt	Steel 1045

Dimensions

Size	L	H	øD
2"	178	265	152
2½"	190	289	178
3"	203	326	190
4"	229	355	229
5"	254	410	254
6"	267	455	279
8"	292	558	343
10"	330	648	406
12"	356	745	483

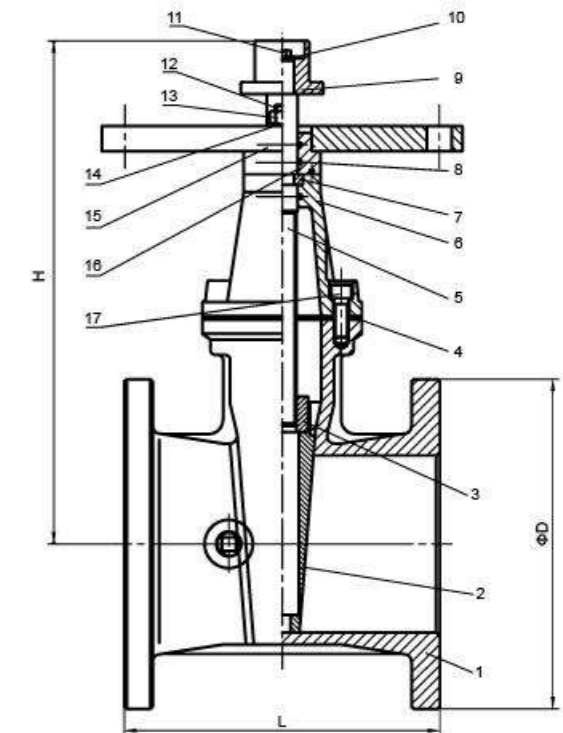

200PSI NRS Flanged x Grooved End Gate Valve Model: Z485

Model: Z485

Resilient Wedge NRS Gate Valve – Flanged x Grooved End

Technical Features

- Nominal Pressure: 200PSI
- Flange Standard: ASME / ANSI B16.1 Class 125 or ASME / ANSI B16.42 Class 150 or BS EN1092-2 PN16 or GB / T9113.1
- Groove standard: ANSI / AWWA C606 or Metric
- Face to Face Standard: ASME B16.10
- Sizes: 2", 2½", 3", 4", 5", 6", 8", 10", 12"
- Approvals: FM, UL, CUL, NSF / ANSI 61 & NSF / ANSI 372
- 2" without UL, CUL
- Maximum Working Pressure: 200PSI (Maximum Testing Pressure: 400 PSI) conforms to UL 262, ULC / ORD C262-92, FM 1120 / 1130
- Maximum Working Temperature: 80°C / 176°F
- Coating Details: Epoxy coated interior and exterior by Electrostatic Spray or Coating upon request
- NPT plug on body with 2 operating nuts
- Certified lead-free by NSF / ANSI 61 & NSF / ANSI 372 is available



Valve Material List

NO.	Name	Material
1	Body	Ductile Iron
2	Disc	Ductile Iron+EPDM
3	Nut	C95400
4	Gasket	EPDM
5	Stem	Stainless Steel 304
6	Cap	Ductile Iron
7	Retainer Ring	C95400
8	O-ring	EPDM
9	Wrench Nut	Ductile Iron
10	Minipad	Steel 1045
11	Bolt	Steel 1045
12	Stud	Steel 1045
13	Nut	Steel 1045
14	Flat Washer	Steel 1045
15	Coupling Flange	Ductile Iron
16	Platen	Ductile Iron
17	Countersunk Head Bolt	Steel 1045

Dimensions

Size	L	H	øD	øD1	øE	F	G
2"	178	265	152	60.3	57.15	15.9	7.9
2½"	190	289	178	76.1	72.3	15.9	7.9
3"	203	326	191	88.9	84.9	15.9	7.9
4"	229	355	229	114.3	110.1	15.9	9.5
5"	254	410	254	141.3	137	15.9	9.5
6"	267	455	279	168.3	163.9	15.9	9.5
8"	292	558	343	219.1	214.4	19	11.1
10"	330	648	406	273	268.3	19	12.7
12"	356	745	483	323.9	318.3	19	12.7

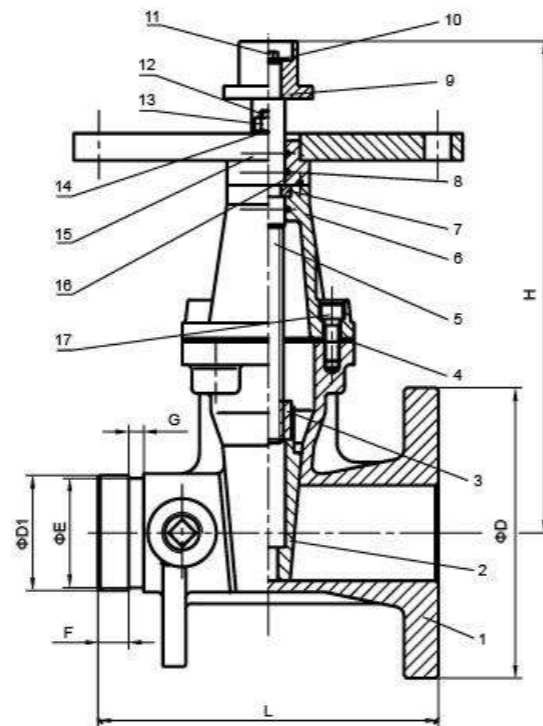

200PSI NRS Grooved End Gate Valve Model: Z85

Model: Z85

Resilient Wedge NRS Gate Valve – Grooved End

Technical Features

- Nominal Pressure: 200PSI
- Groove standard : ANSI / AWWA C606 or Metric
- Face to Face Standard: ASME B16.10
- Sizes: 2", 2½", 3", 4", 5", 6", 8", 10", 12"
- Approvals: FM, UL, CUL, NSF / ANSI 61 & NSF / ANSI 372
- 2" without UL, CUL
- Maximum Working Pressure: 200PSI (Maximum Testing Pressure: 400 PSI) conforms to UL 262, ULC / ORD C262-92, FM 1120 / 1130
- Maximum Working Temperature: 80°C / 176°F
- Coating Details: Epoxy coated interior and exterior by Electrostatic Spray or Coating upon request
- NPT plug on body with 2 operating nuts
- Certified lead-free by NSF / ANSI 61 & NSF / ANSI 372 is available



Valve Material List

NO.	Name	Material
1	Body	Ductile Iron
2	Disc	Ductile Iron+EPDM
3	Nut	C95400
4	Gasket	EPDM
5	Stem	Stainless Steel 304
6	Cap	Ductile Iron
7	Retainer Ring	C95400
8	O-ring	EPDM
9	Wrench Nut	Ductile Iron
10	Minipad	Steel 1045
11	Bolt	Steel 1045
12	Stud	Steel 1045
13	Nut	Steel 1045
14	Flat Washer	Steel 1045
15	Coupling Flange	Ductile Iron
16	Platen	Ductile Iron
17	Countersunk Head Bolt	Steel 1045

Dimensions

Size	L	H	øD	øE	F	G
2"	178	265	60.3	57.15	15.9	7.9
2½"	190	289	76.1	72.3	15.9	7.9
3"	203	326	88.9	84.9	15.9	7.9
4"	229	355	114.3	110.1	15.9	9.5
5"	254	410	141.3	137	15.9	9.5
6"	267	455	168.3	163.9	15.9	9.5
8"	292	558	219.1	214.4	19	11.1
10"	330	648	273	268.3	19	12.7
12"	356	745	323.9	318.3	19	12.7

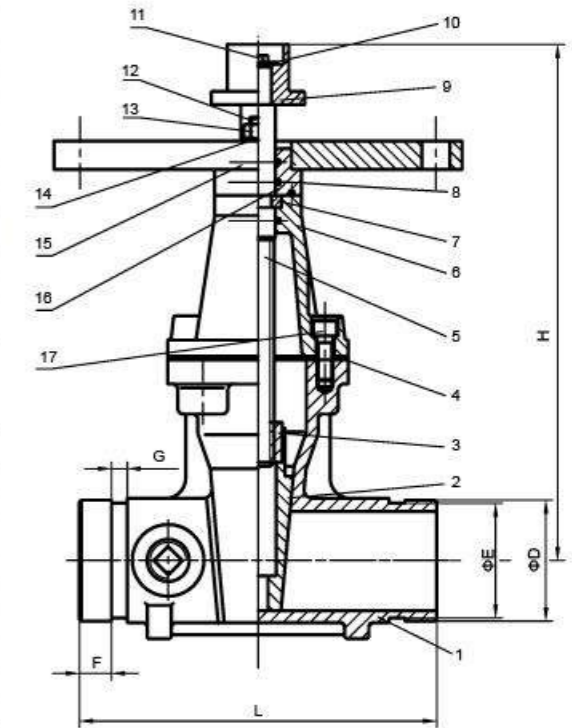

300PSI Flanged Swing Check Valve

Model: MH-XQH-300

Flanged End

Technical Features

- Nominal Pressure: 300PSI
- Conforms: AWWA C508
- Flange Standard: ASME / ANSI B16.1 Class 125 or ASME / ANSI B16.42 Class 150 or BS EN1092-2 PN16 or GB / T9113.1
- Sizes: 2", 2½", 3", 4", 5", 6", 8", 10", 12"
- Face to Face Standard: ASME B16.10
- Approvals: UL, FM
- Maximum Working Pressure: 300PSI (Maximum Testing Pressure: 600PSI) conforms to UL 312 & FM class 1210
- Working Temperature: 80°C / 176°F
- Coating Details: Epoxy coated interior and exterior by Electrostatic Spray or coating upon request
- Applications:
 - Used both vertically and horizontally;
 - Used in one-way flow pipeline to prevent the water from back flow

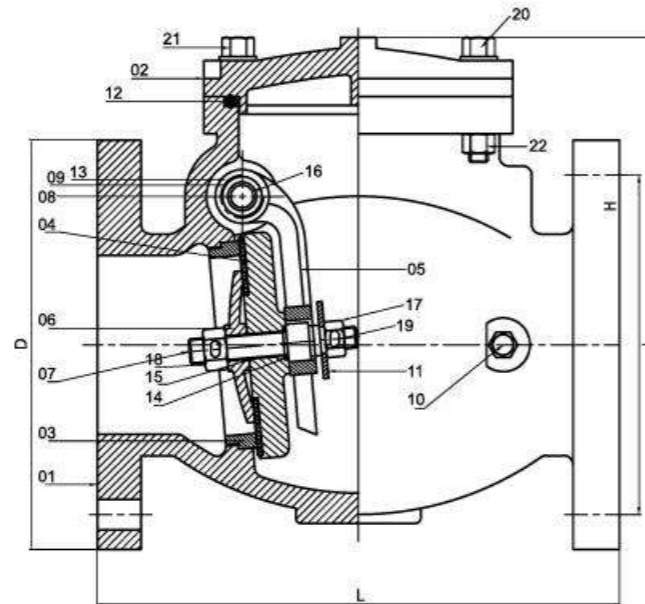

Dimensions

Size	DN	L	D	H
2"	DN50	203	152	142
2½"	DN65	216	178	148
3"	DN80	241	191	163.5
4"	DN100	292	229	172
5"	DN125	330	254	237
6"	DN150	356	279	233
8"	DN200	495	343	301
10"	DN250	622	406	348
12"	DN300	698	483	419

Valve Material List

NO.	Name	Material
1	Body	Ductile Iron
2	Bonnet	Ductile Iron
3	Seat Ring	C95400
4	Disc	Ductile Iron+EPDM
5	Rocker Arm	Ductile Iron
6	Baffle Plate	C95400
7	Middle Stem	Stainless Steel 304
8	Stem	Stainless Steel 304
9	Bracket Screw	Stainless Steel 304
10	Plug	C95400
11	Gasket	Stainless Steel 304
12	O-ring	EPDM
13	O-ring	EPDM
14	O-ring	EPDM
15	O-ring	EPDM
16	Bronze Bushing	Powder Metallurgy
17	Nut	Stainless Steel 304
18	Nut	Stainless Steel 304
19	Cotter Pin	Stainless Steel 304
20	Bolt	Steel 1045
21	Bolt	Steel 1045
22	Nut	Steel 1045

350PSI Grooved Swing Check Valve

Model: MH-XQH-350G

Grooved End

Technical Features

- Nominal Pressure: 350PSI
- Groove standard : ANSI / AWWA C606 or Metric
- Sizes: 2", 2½", 3", 4", 5", 6", 8", 10", 12"
- Approvals: UL, FM
- Flange Standard: ASME / ANSI B16.1 Class 125 or ASME / ANSI B16.42 Class 150 or BS EN1092-2 PN16 or GB / T9113.1
- Maximum Working Pressure: 350PSI (Maximum Testing Pressure: 700 PSI) conforms to UL 312 & FM class 1210
- Maximum Working Temperature: 80°C / 176°F
- Coating Details: Epoxy coated interior and exterior by Electrostatic Spray or coating upon request
- Applications: Used in one-way flow pipeline to prevent the water from back flow
- Other Connections: Flange*Flange; Groove*Flange; Flange*Groove



Valve Material List

NO.	Name	Material
1	Valve Body	Ductile Iron
2	Bolt	Steel 1045
3	Plug	Steel 1045
4	Plug	Steel 1045
5	Spring	Stainless Steel 304
6	Hinge Pin	Stainless Steel 304/Ductile Iron
7	Clapper	Stainless Steel 304
8	Seat	C95400
9	Clamping Ring	Stainless Steel 304
10	Locknut	Stainless Steel 304
11	Facing Seal	EPDM
12	Gasket	EPDM
13	Bolt	Stainless Steel 304
14	Plug	Steel 1045

Dimensions

Size	L	D1	D2	B	C	P1			P2			P3			
						Rc½-14	Rc½-14	Rc¾-14	Rc1-11	Rc1 ½-11	Rc1 ½-11	Rc2-11	Rc¾-19	Rc¾-19	Rc½-14
2"	169	57.15	60.3	7.95	15.88	½-14NPT	½-14NPT	¾-14NPT	1-11.5NPT	1 ½-11.5NPT	1 ½-11.5NPT	2-11.5NPT	¾-18NPT	¾-18NPT	½-14NPT
2½"	181	69.09	73	7.95	15.88	½-14NPT	½-14NPT	¾-14NPT	1-11.5NPT	1 ½-11.5NPT	1 ½-11.5NPT	2-11.5NPT	¾-18NPT	¾-18NPT	½-14NPT
3"	198	84.94	88.9	7.95	15.88	½-14NPT	½-14NPT	¾-14NPT	1-11.5NPT	1 ½-11.5NPT	1 ½-11.5NPT	2-11.5NPT	¾-18NPT	¾-18NPT	½-14NPT
4"	214	110.08	114.3	9.53	15.88	½-14NPT	½-14NPT	¾-14NPT	1-11.5NPT	1 ½-11.5NPT	1 ½-11.5NPT	2-11.5NPT	¾-18NPT	¾-18NPT	½-14NPT
5"	248	135.48	139.7	9.53	15.88	½-14NPT	½-14NPT	¾-14NPT	1-11.5NPT	1 ½-11.5NPT	1 ½-11.5NPT	2-11.5NPT	¾-18NPT	¾-18NPT	½-14NPT
6"	270	160.78	165.1	9.53	15.88	Rc½-14	Rc½-14	Rc¾-14	Rc1-11	Rc1 ½-11	Rc1 ½-11	Rc2-11	Rc¾-19	Rc¾-19	Rc½-14
	163.96	168.3	½-14NPT			½-14NPT	¾-14NPT	1-11.5NPT	1 ½-11.5NPT	1 ½-11.5NPT	2-11.5NPT	¾-18NPT	¾-18NPT	½-14NPT	
8"	325	211.6	216.3	11.13	19.05	Rc½-14	Rc½-14	Rc¾-14	Rc1-11	Rc1 ½-11	Rc1 ½-11	Rc2-11	Rc¾-19	Rc¾-19	Rc½-14
	214.4	219.1	½-14NPT			½-14NPT	¾-14NPT	1-11.5NPT	1 ½-11.5NPT	1 ½-11.5NPT	2-11.5NPT	¾-18NPT	¾-18NPT	½-14NPT	
10"	457	268.3	273	12.7	19.05	Rc½-14	Rc½-14	Rc¾-14	Rc1-11	Rc1 ½-11	Rc1 ½-11	Rc2-11	Rc¾-19	Rc¾-19	Rc½-14
	268.3	273	½-14NPT			½-14NPT	¾-14NPT	1-11.5NPT	1 ½-11.5NPT	1 ½-11.5NPT	2-11.5NPT	¾-18NPT	¾-18NPT	½-14NPT	
12"	535	318.3	323.9	12.7	19.05	Rc½-14	Rc½-14	Rc¾-14	Rc1-11	Rc1 ½-11	Rc1 ½-11	Rc2-11	Rc¾-19	Rc¾-19	Rc½-14
	318.3	323.9	½-14NPT			½-14NPT	¾-14NPT	1-11.5NPT	1 ½-11.5NPT	1 ½-11.5NPT	2-11.5NPT	¾-18NPT	¾-18NPT	½-14NPT	

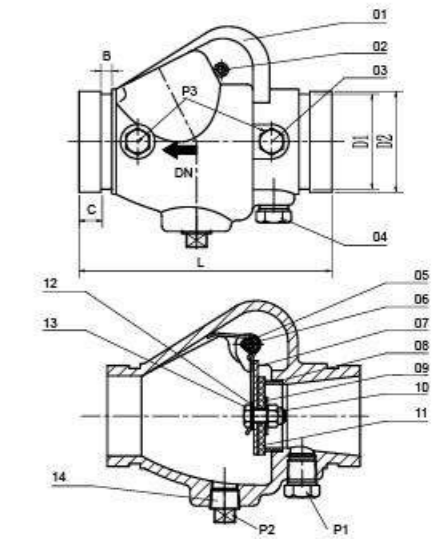

Vertical Type Indicator Post

Model: ZSQ

Technical Features

- Approvals: UL, CUL, FM
- Conforms to UL 789 & ULC / ORD-C789 & FM 1110
- Adjustable buried length: 570mm to 1500mm
- Used to identify the position of buried Gate Valves from 4" to 12"

Operation Manual

- Remove the indicator cover
- Adjust the length of the connecting rod according to buried depth and cut off the excessive part
- Connect the indicator post and gate valve which is in the closed position
- Adjust the indicator to the position of "SHUT"
- Tighten the bolts between the flange of the indicator post and post flange of gate valve
- Install the indicator cover

Material List

NO.	Name	Material
1	Handle	Ductile Iron
2	Driving Rod	Stainless Steel 304
3	Indicator Cover	Cast Iron
4	Housing	Cast Iron
5	Keyhole Plate	A283 Gr.C
6	Indicator Plate	A413.0
7	Screwed Plug	Steel 1035
8	Extension Rod	A283 Gr.C
9	Flange	Cast Iron
10	Connecting Rod	Steel 1045
11	Cotter Pin	Steel 1035
12	Joint	Cast Iron
13	Bolt	Steel 1035
14	Bolt	Steel 1035
15	Bolt	Steel 1035
16	Driving Nut	Stainless Steel 304
17	Keyhole Plate Gasket	EPDM
18	Indicator Flap	Organic Glass
19	Bolt	Steel 1035

Dimensions

Size	H(mm)(200PSI)		H(mm)(300PSI)	
	MIN.	MAX.	MIN.	MAX.
4"	850	1780	825	1755
5"	880	1810	890	1820
6"	917	1847	926	1856
8"	1022	1952	1012	1942
10"	1115	2045	1108	2038
12"	1204	2134	1188	2118

3D Picture

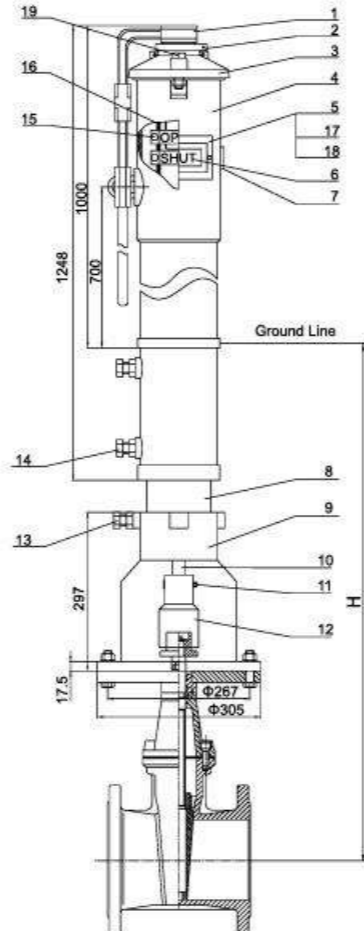
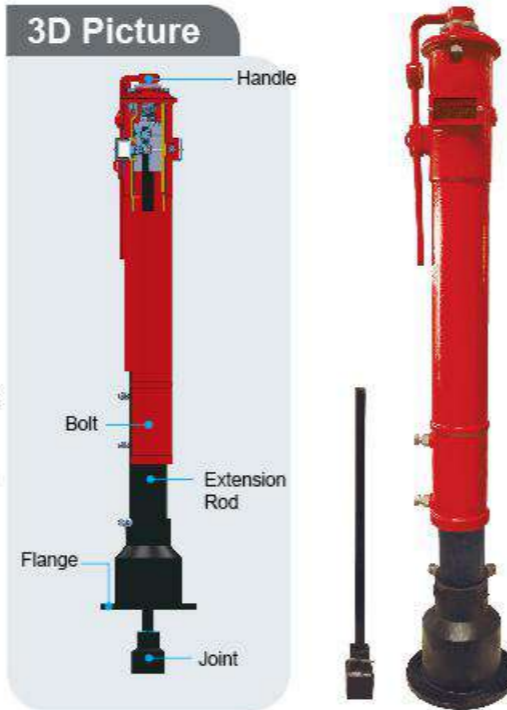

Wall Type Indicator Post

Model: QSCZG

Technical Features

- Approvals: UL, CUL, FM
- Conforms to UL 789 & ULC / ORD-C789 & FM 1110
- Used to Operate a Valve Installed Behind the Wall

3D Picture

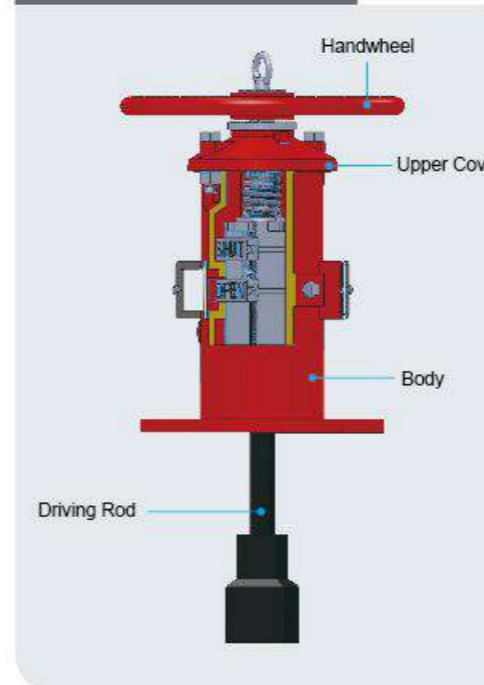

Operation Manual

- Adjust the length of the connecting rod according to the depth of gate valve and cut off the excessive part
- Install the indicator post to the wall
- Connect the indicator post and gate valve which is in the closed position
- Adjust the indicator to the position of "SHUT"

Material List

NO.	Name	Material
1	Joint	Cast Iron
2	Cotter Pin	Steel 1035
3	Driving Rod	Steel 1045
4	Main Body	Cast Iron
5	Indicator Plate	A413.0
6	Nut, Gasket	Steel 1035
7	Stud Bolt	Steel 1035
8	Position Bracket	Stainless Steel 304
9	Driver	Stainless Steel 304
10	Retainer Ring For Stem	1566
11	Upper Cover	Cast Iron
12	Handwheel	Cast Iron
13	Gasket	A283 Gr.C
14	Lift Ring	Steel 1035
15	Screw	Steel 1035
16	Nut	Steel 1035
17	Bolt	Steel 1035
18	Screwed Plug	Steel 1035
19	Bolt, Flat Gasket	Stainless Steel 304
20	Keyhole Plate	A283 Gr.C
21	Keyhole	Organic Glass
22	Keyhole Plate Gasket	EPDM

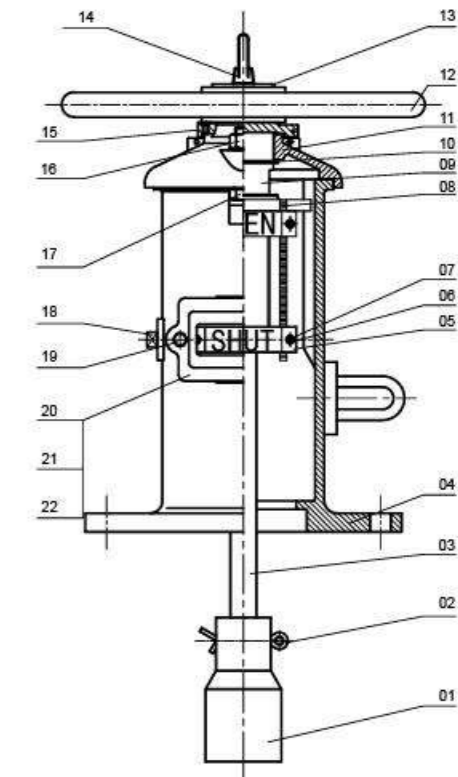

Dry Barrel Fire Hydrant

Model: MH-1510FA/MH-1510A

Technical Features

- Nominal Pressure: 250PSI
- Design Standard: AWWA C502
- Inlet flange size: 6" (DN150), Main Valve size: 133.4 mm / 5-1/4"
- One pumper nozzle: 4.5-4NH thread. Two hose nozzles, 2.5-7.5NH threads
Other kinds of threads are available
- Mechanical connector: AWWA / ANSI C153 / A21.536, Model No.: MH-1510A
- Flange connector: ASME B16.5 CLASS 150/DIN 2501 PN16, Model No.: MH-1510FA
- Painting Details: Red Polyurethane paint & Bitumen Black or painting upon request
- Note: Each hydrant is supplied with a hydrant wrench
- Approvals: UL 246 Listed, FM 1510 Approved

Installation

- Hydrants should be handled with care to avoid damage. It is recommended to keep hydrants closed until use
- If the hydrant is not to be used straight away then it is recommended to coat threads and other machined parts with anti-rust oil and the hydrant should be stored in a dry and ventilated area. For long-term storage, the hydrant should be checked regularly
- Before installation of hydrants, the connection should be free from dirt or other matter
- The positioning of the hydrant should be in accordance with local requirements. Ideally the pumper should face the street and all connections should be away from any obstruction to connecting hoses
- The inlet elbow should be placed on a solid surface and if possible brace the side opposite the incoming flow to reduce reaction stresses
- The underground parts of the hydrant should be surrounded with coarse gravel for support and drainage
- After the hydrant has been installed and tested, it is recommended to fully flush the hydrant before closing for service. Before replacing the nozzle caps, it is recommended to check for correct drainage of the hydrant on closing of the valve. This can be achieved by placing a hand over the nozzle opening, a suction should be felt

Operation

- Unscrew the nozzle caps and connect hoses
- Open the hydrant using the hydrant key (included) to the fully open position by turning the operation nut in an anti-clockwise direction. Do not force the hydrant to open further past the fully open position. Note that the hydrant valve is not intended to control the flow, it should be used in either the fully open or fully closed position
To control flow, a pressure/flow control valve should be fitted to the nozzle outlets on the hydrant
- To close, turn the operation nut into a clockwise direction again, do not over tighten



3D Pictures

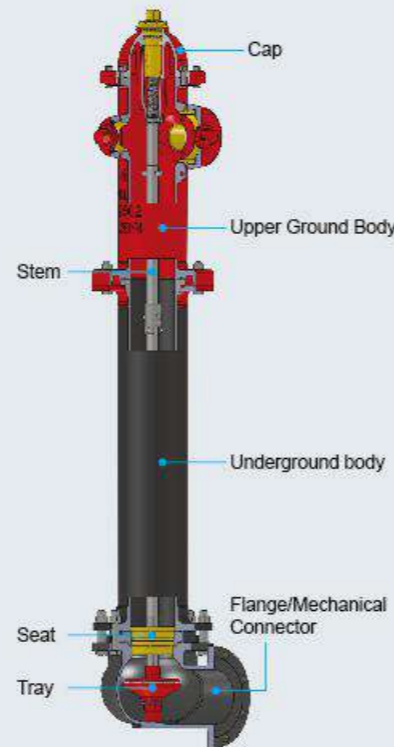

Fire Hydrant

Model: MH-1510FA/MH-1510A

Maintenance

- Carry out a visual inspection for signs of significant corrosion which may impair performance
- Where possible, carry out leakage tests by opening one of the nozzle caps slightly and then open the hydrant valve
Once the air has escaped, tighten the hose cap and check for leaks
- Close hydrant and remove one nozzle cap so that the drainage can be checked
- Flush the hydrant
- Clean and lubricate all nozzle threads
- Clean the exterior of the hydrant and repaint if required

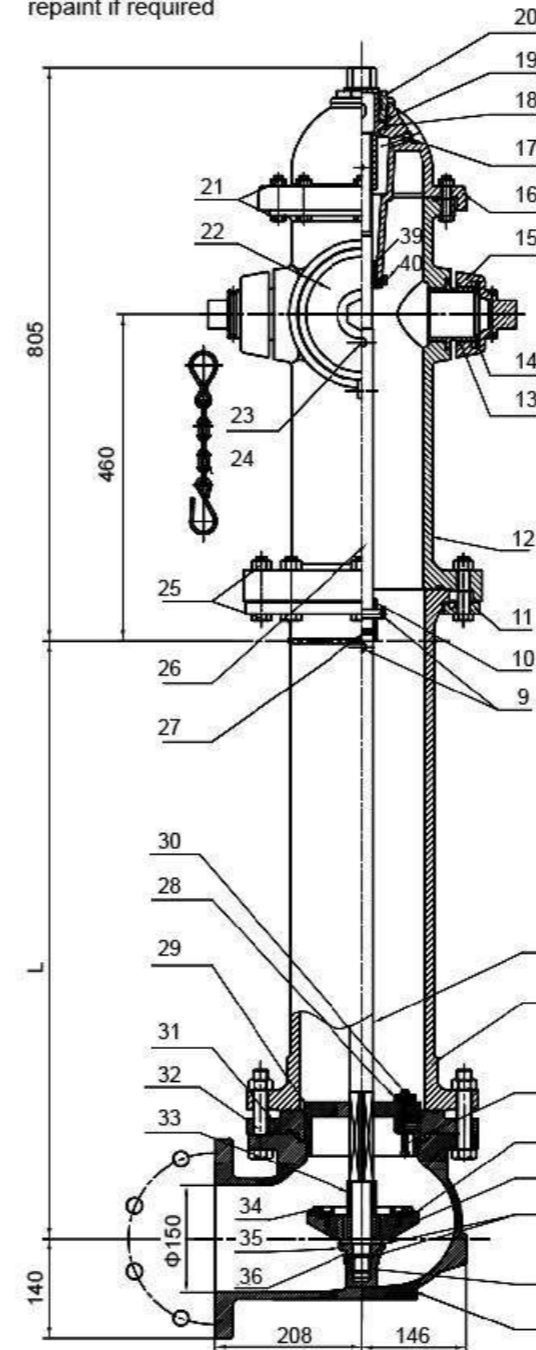

Buried Dimensions

L (mm)	3'6"	4'	4'6"	5'	5'6"	6'	6'6"	7'
	1063	1215	1368	1520	1673	1825	1978	2130

Material List

NO.	Name	Material
1	Flange Connector Or Mechanical Connector	Ductile Iron
2	Locking Nut	Ductile Iron
3	Connecting Rod	Steel 1045
4	Locking Nut Gasket	EPDM
5	Tray	Ductile Iron
6	Sealed Rubber Sheet	EPDM
7	Drain Hole Spring	316 Stainless Steel
8	Connecting Cylinder	Ductile Iron
9	Perforated Cylindrical Pin	Steel 1045
10	Connecting Rod Sleeve	Steel 1045
11	Clamp For Connection Tube	Ductile Iron
12	Main Body On Ground	Ductile Iron
13	65 Connector	C95400
14	65 Cover Gasket	EPDM
15	65 Cover	Ductile Iron
16	Upper End Cover	Ductile Iron
17	Thread Plug	C95400
18	Screw Stem Nut	C95400
19	Screw Nut Gasket	C95400
20	Screw Nut Seat	C95400
21	Bolt,nut	Steel 1035
22	100 Cover	Ductile Iron
23	Cylindrical Pin	Steel 1045
24	Cover Chain	Gr.B, ASTM A283-B
25	Bolt,nut	Steel 1035
26	Screw Stem	Steel 1045
27	Cushion Rubber	EPDM
28	Drain Hole Cover	C95400+EPDM
29	Seat	C95400
30	Bolt,nut	316 Stainless Steel
31	Seat Fixing Plate	Ductile Iron
32	Bolt,nut	Steel 1035
33	Annular Tubes	Steel 1045
34	Platen	Ductile Iron
35	Locking Nut Seat	Ductile Iron
36	Check Turn Gasket	Gr.B
37	100 Connector	C95400
38	100 Cover Gasket	EPDM
39	Screw Stem Bushing	316 Stainless Steel
40	Bolt	316 Stainless Steel

Wet Hydrant

Model: MH-1511/1511A/1512/1512A

Air Release Valves

Model: MH-AMARV

Technical Features

- Design Standard: AWWA C503
- External Thread Standard: NFPA 1963 2.5"-7.5NH/4"-4NH/4.5"-4NH
- Water Inlet Flange Standard: ASTM B16.5 Class150 6"/DIN2501 PN16 DN150
- Maximum Adjust Pressure: 250PSI
- Monitor Flange Standard: ASTM B16.5 Class150 4"/DIN2501 PN16 DN100
- Working Temperature : 0°C-80°C

Valve Material List

NO.	Name	QTY	Material
1	Main Body	1	Ductile Iron
2	Nut	3	C954
3	2.5"Bolt	2	SS304/C954
4	4.5"Bolt	1	SS304/C954
5	Stem cap	3	Ductile Iron
6	Bolt	3	SS304
7	2.5"Tray	2	Ductile Iron/SS304/C954
8	4.5"Tray	1	Ductile Iron/SS304/C954
9	2.5"Sealing rubber sheet	2	EPDM
10	4.5"Sealing rubber sheet	1	EPDM
11	2.5"Platen	2	Ductile Iron/SS304/C954
12	4.5"Platen	1	Ductile Iron/SS304/C954
13	2.5"Outlet	2	C954
14	4.5"Outlet	1	C954
15	2.5"Outlet cover	2	Ductile Iron
16	4.5"Outlet cover	1	Ductile Iron
17	2.5"Cover gasket	2	EPDM
18	4.5"Cover gasket	1	EPDM
19	Cotter pin	3	SS304
20	Slotted nut	3	SS304
21	Cover chain		Gr.B

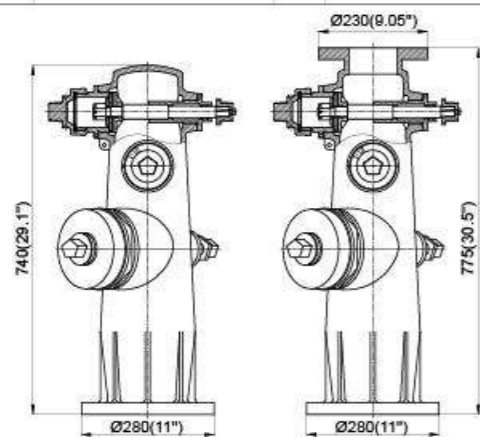
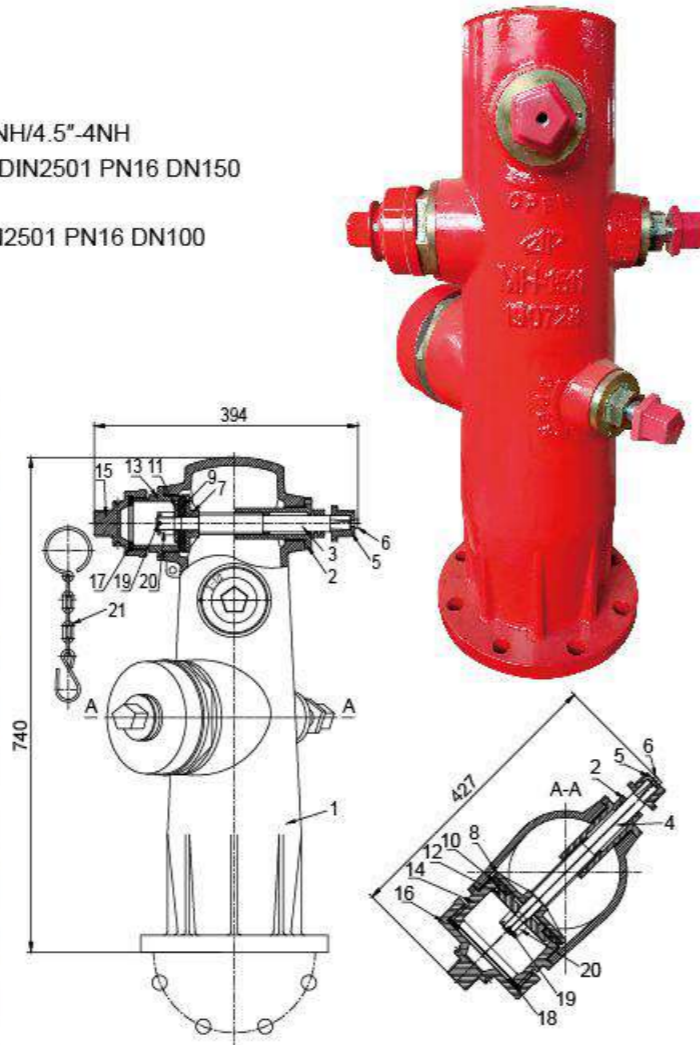

General Technical Information

Model Number	House Outlet Size	Pumper Hozzle Size	Monitor
MH-1511	2X2.5"	1X4.5"	N/A
MH-1511A	2X2.5"	1X4.5"	YES
MH-1512	2X2.5"	1X4"	N/A
MH-1512A	2X2.5"	1X4"	YES

NPT and BSPT Type

Technical Features

- Designed, manufactured: accordance with UL 2573/FM1344.
 - Test Standard:UL 2573/FM1344.
 - Temperature: 0 to 100°C
 - Normal size: 1"
 - Normal Pressure:175PSI
 - Test Pressure: Leakage Test 7PSI/263PSI, Strength Test 350PSI
 - Use in wet pipe sprinkler systems, or with horizontal split case pumps.
 - The inlets of the valves are 1-11 1/2NPT or R_c 1, the outlets of the valves are 1/2-14NPT or R_c 1/2.
- Advantages: This valve can ensure the excellent leak tightness and good venting capabilities under the rated working pressure.



Valve Material List

S./N.	Description of Parts	Materials
1	Valve Body	Ductile Iron
2	Filter Screen	SS316
3	Gasket Ring	Carbon Steel
4	Bonnet	Ductile Iron
5	Yoke	SS316
6	Valve Seat	SS316
7	Bolt	SS316
8	Valve Shaft	SS316
9	E Type Retainer Ring	SS304
10	Ball	SS316
11	Big Protective Cover	Plastic
12	Lever	SS316
13	Poppet	EPDM
14	Spring Washer	SS316
15	Hex Socket Head Bolt	SS304
16	Asbestos-free Gasket	CN-705
17	Spring Washer	Carbon Steel
18	Bolt	Carbon Steel
19	Plug	Ductile Iron
20	Small Protective Cover	Plastic

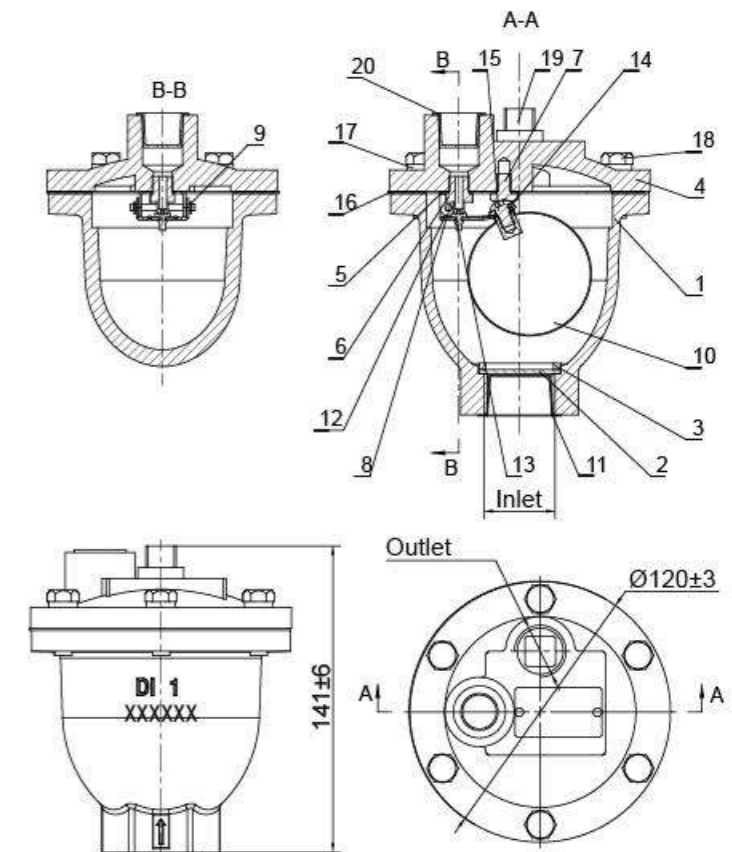

Connections for Installation

- The inlet connections shall be made using the external threads of tapered pipe thread 1-11 1/2NPT conforming to the standard ASME B 1.20.1-2013, and the outlet connections shall be made using the external threads of tapered pipe thread 1/2-14NPT conforming to the standard ASME B 1.20.1-2013.
- The inlet connections shall be made using the external threads of tapered pipe thread R21 conform to the standard ISO 7-1-1994, and the outlet connections shall be made using the external threads of tapered pipe thread R2 1/2 conforming to the standard ISO 7-1-1994.

Vane Type Water Flow Switch

Model: ZSJZ-YM-450

Technical Features

- Size: DN50-DN200 / 2"- 8"
- Working Pressure: 450PSI
- Sensitivity:
 - FM: 1. No-alarm flow $\leq 15\text{L}/\text{min}$
 - 2. Alarm flow $> 15\text{L}/\text{min}, \leq 75\text{L}/\text{min}$
 - UL: 1. No-alarm flow $\leq 15\text{L}/\text{min}$
 - 2. Alarm flow $> 15\text{L}/\text{min}, \leq 37.5\text{L}/\text{min}$
- Capacity of Switch Contacts:
 - AC 125/250V 8A
 - DC 24V 3A
 - DC 30V 2.5A
- Working Temperature: 0-49°C
- Steel Pipe: SCH10-40
- 0-90 Seconds Field Replaceable Retard



Technical Information

- I. Overview

The vane type water flow switch use in wet pipe systems only. Water flow in the pipe deflects a vane, which produces a switched output usually after a specified delay.
- II. Main Components

ZSJZ series water flow indicator is mainly composed of the saddle, blade rack, bottom plate, outer cover, Air delay device, micro-switch, junction box, etc.

 1. The main outline drawing is shown in Figure 1 Outline Drawing.
 2. Main dimensions of water flow indicator are shown in Table 1.
 3. Materials of the main components are shown in Table 2.

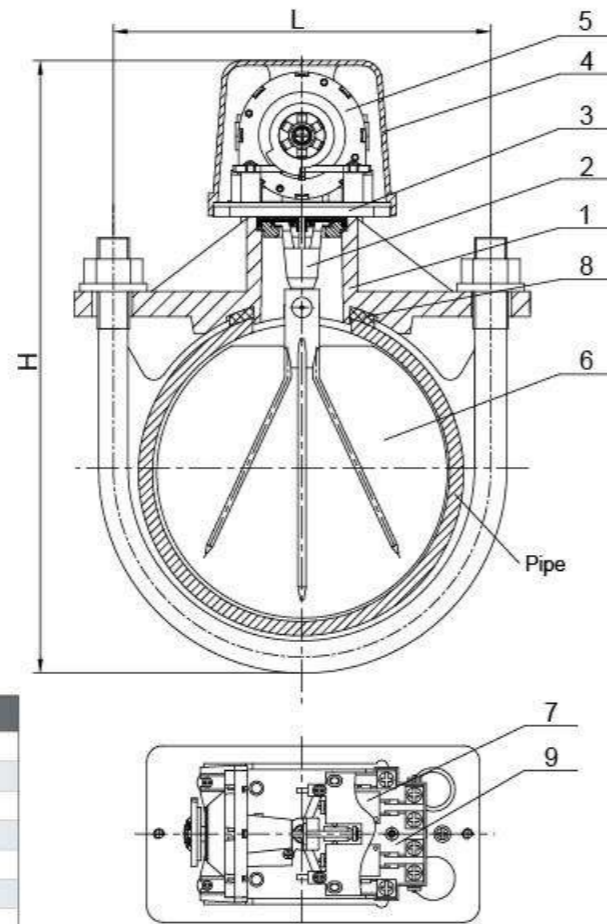

Figure 1 Outline Drawing

Dimensions

Model	Specification	INCH	L	H
ZSJZ-YM-450	DN50	2"	85	188
ZSJZ-YM-450	DN65	2.5"	92	200
ZSJZ-YM-450	DN80	3"	106	220
ZSJZ-YM-450	DN100	4"	134	245
ZSJZ-YM-450	DN125	5"	162	272
ZSJZ-YM-450	DN150	6"	189.5	298
ZSJZ-YM-450	DN200	8"	240	350

Table 1

Vane Type Water Flow Switch

Model: ZSJZ-YM-450

Installation and Debugging as well as Precautions

- Installation of water flow indicator:
 - at the pre-set installation position, use a tapper to drill on the main pipeline and remove burrs according to the product specification;
 - roll up the blade into a small size and put it into the pipeline, install the U-shaped bolt and fasten it up with two fastening nuts, and the specific installation drawing is shown in Figure 2.

Materials of Main Components

No.	Name	Materials
1	Body	Ductile Iron
2	Blade Rack	SS304+EPDM
3	Bottom Plate	SS304
4	Outer Cover	Aluminum
5	Air Delay Device	Component
6	Blade	LLDPE
7	Micro-switch	Component
8	Sealing Gasket	EPDM
9	Junction Box	PC

Table 2

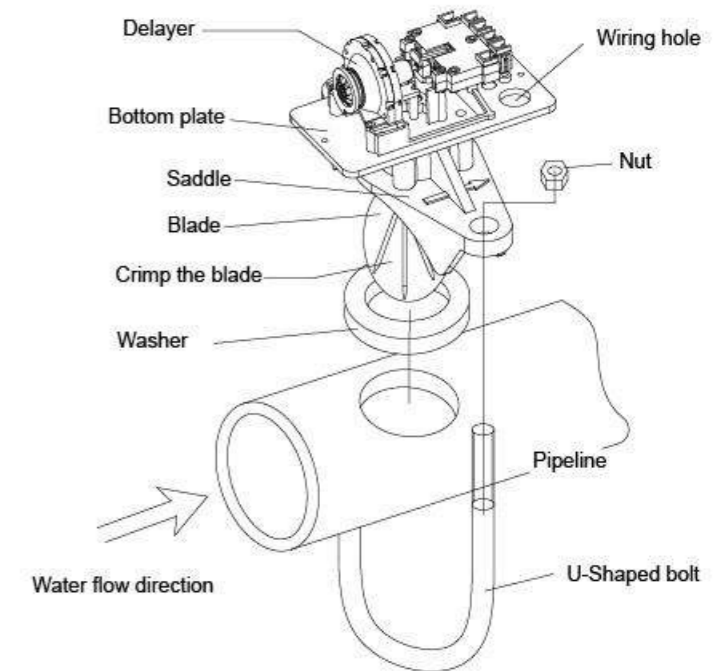

Figure 2 Installation Drawing

The typical wiring diagram is shown in Figure 3

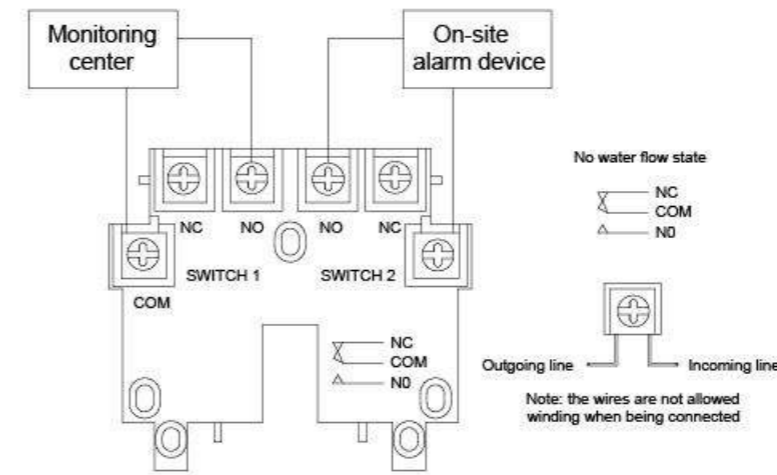

Figure 3

The hole size is shown in Table 3

Specification	Hole size
DN50, DN65	32+2mm
DN80-DN200	51+2mm

Table 3

Wet Alarm Check Valve

Model: SSBJ-300GG/SSBJ-300FF/SSBJ-300FGA/SSBJ-300FGB

Flange/Groove/Flange*Groove/Groove*Flange

Technical Features

- Maximum Adjust Pressure: 200PSI-300PSI/PN10/PN16
- Flange Standard: ASME/ANSI B16.1 Class 125 or ASME/ANSI B16.42 CLASS 150 or BS EN1092-2 PN16 or GB/T9113.1
- Groove Standard: AWWA C606/ISO 6182-12
- Working Temperature: 4°C-70°C
- Installation Height of the Gong According to Clients' requirements
- Gong can be Installed indoor or outdoor through wall as to clients' requirements
- External Dimensions for reference only
- Coating details: Epoxy coated interior and exterior by Electrostatic Spray or Coating upon request
- Alarm check valves use in wet pipe of sprinkler system, Fire protection system



Valve Material List

Size	Name	Material	QTY.
1	Alarm Valve		1
2	Orifice,retard	C954/SS304	1
3	Tee	Steel/SS304	2
4	Nipple	Steel/SS304	6
5	Union	Steel/SS304	1
6	Nipple	Steel/SS304	1
7	Y Strainer	C954/SS304	1
8	Retard Chamber	Steel	1
9	Gong Assembly	Component	1
10	Nipple	Steel/SS304	1
11	Reducer Bushing	Steel/SS304	1
12	Pressure Switch	Component	1
13	Cross	Steel/SS304	1
14	Reducer Bushing	Steel/SS304	1
15	Plug	Steel/C954/SS304	1
16	Cross	Steel/SS304	2
17	Pressure Gauge	Component	3
18	3-way Valve Gauge	C954/SS304	3
19	Plug	Steel/C954/SS304	3
20	Orifice,retard	C954/SS304	1
21	Check Valve	C954/SS304	1
22	Nipple	Steel/SS304	1
23	Nipple	Steel/SS304	3
24	Tee	Steel/SS304	2
25	Nipple	Steel/SS304	4
26	Nipple	Steel/SS304	1
27	Nipple	Steel/SS304	1
28	Ball Valve	C954/SS304	1
29	Nipple	Steel/SS304	1
30	Ball Valve	C954/SS304	1
31	Elbow	Steel/SS304	2
32	Nipple	Steel/SS304	1
33	Ball Valve	C954/SS304	1

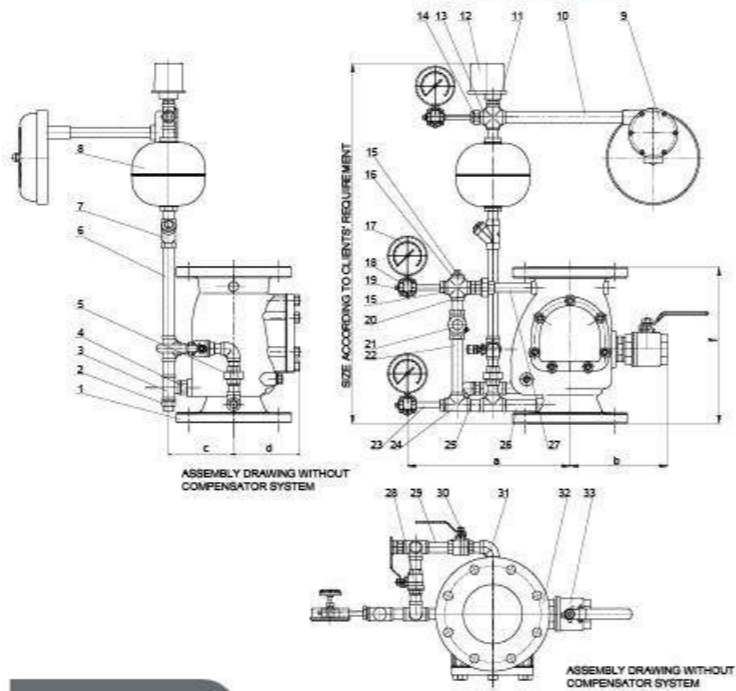

Dimensions

Size	a	b	c	d
2"	340	205	145	110
2.5"	340	205	145	110
3"	340	205	145	110
4"	342	250	160	136
5"	349	274	180	162
6"	349	274	180	162
8"	415	290	205	195
10"	475	340	240	235
12"	495	368	270	270

General Technical Information

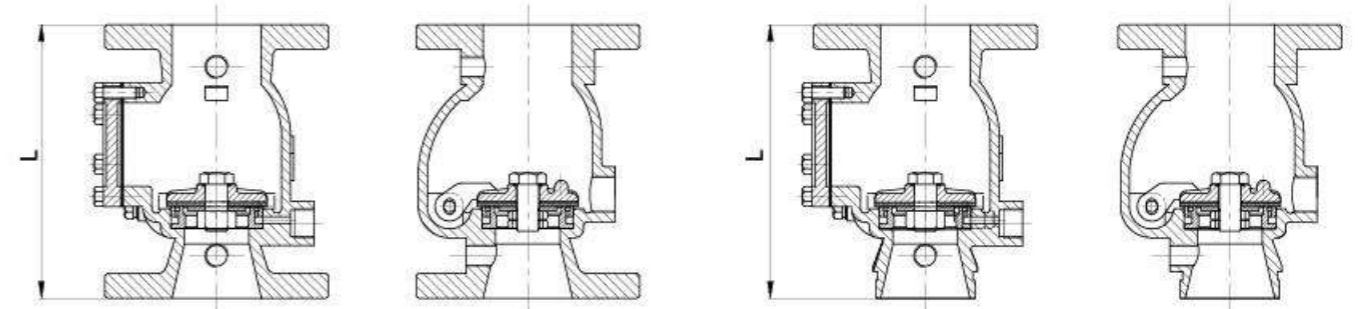

Flange*Flange

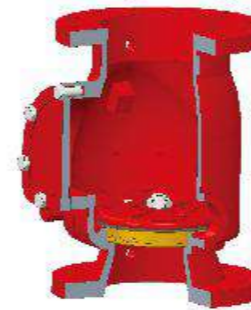

Dimension Chart

Size	L(mm)	L(inch)
DN50(2in)	233	9.17
DN65(2.5in)	236	9.29
DN80(3in)	245	9.65
DN100(4in)	316	12.44
DN125(5in)	386	15.20
DN150(6in)	390	15.35
DN200(8in)	438	17.24
DN250(10in)	535	21.06
DN300(12in)	622	24.49

Flange*Groove



Dimension Chart

Size	L(mm)	L(inch)
DN50(2in)	239	9.41
DN65(2.5in)	240	9.45
DN80(3in)	245	9.65
DN100(4in)	316	12.44
DN125(5in)	386	15.20
DN150(6in)	390	15.35
DN200(8in)	438	17.24
DN250(10in)	535	21.06
DN300(12in)	622	24.49

Groove*Flange



Dimension Chart

Size	L(mm)	L(inch)
DN50(2in)	239	9.41
DN65(2.5in)	240	9.45
DN80(3in)	245	9.65
DN100(4in)	316	12.44
DN125(5in)	386	15.20
DN150(6in)	390	15.35
DN200(8in)	438	17.24
DN250(10in)	535	21.06
DN300(12in)	622	24.49

Groove*Groove



Dimension Chart

Size	L(mm)	L(inch)
DN50(2in)	245	9.65
DN65(2.5in)	245	9.65
DN80(3in)	245	9.65
DN100(4in)	316	12.44
DN125(5in)	386	15.20
DN150(6in)	390	15.35
DN200(8in)	438	17.24
DN250(10in)	535	21.06
DN300(12in)	622	24.49

Pressure Switch

Model: ZSJY 1.6BP

Technical Features

- Dimension: 121mm(4 3/4")*57mm(2 1/4")*111mm(4 3/8")
- Wiring Inlet: 1/2"
- Pressure Connection: Nylon 1/2" NPT thread
- Outer Cover: die casting with red coating
- Base: Galvanized carbon steel
- Factory Setting: 5-7 PSI (cannot be adjusted after consignment)
- Differential Pressure: 1 PSI (cannot be adjusted after consignment)
- Maximum Working Pressure: 250 PSI
- Switch Contact: double SPDT
- Contact Capacity: 15 Amps under 125/250 VAC, 2.5 Amps under 30 VDC
- Dust Proof and Waterproof Lever: IP66
- Temperature Range: -40°C to 60°C
- Tamper proof fasteners on outer cover

Technical Specifications

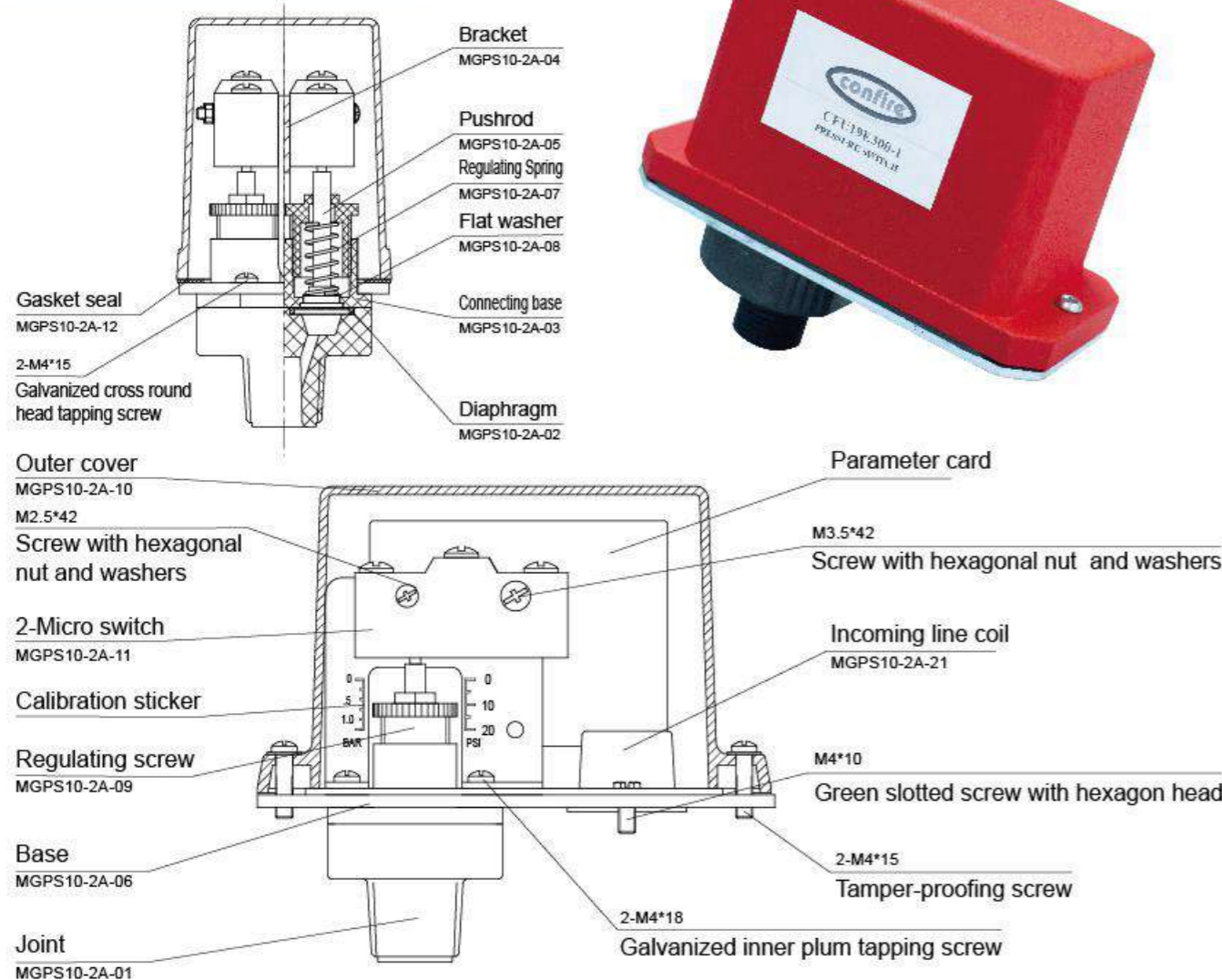

Pressure Gauge

Model: PFE-00A/00B

Technical Features

- Pressure Gauge for Fire Protection system
- Designed and manufactured in accordance with UL 393/FM2311
- Test Standard: UL 393/FM2311
- Temperature: 0 to 80°C
- Nominal Size: 1/4" NPT
- Nominal Pressure: 0-300PSI,0-600PSI

Material List

NO.	Name	Material
1	Base	HPb59-1
2	Watchcase	1008
3	Spring pipe	Qsn0.8-2
4	Rivet	HPb59-1
5	Connecting rod	H62
6	Free end	H62
7	Inner core combination	HPb59-1
8	Dial plate	HPb59-1
9	Pointer component	Al
10	Watchcase	PC
11	Rivet column	HPb59-1

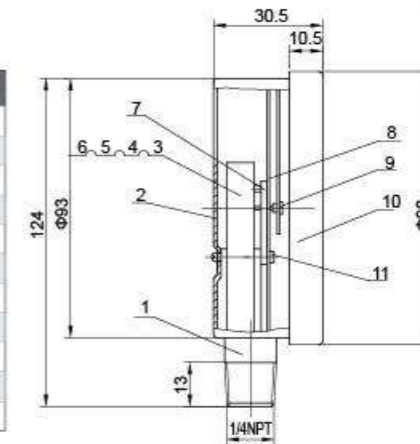

Water Motor Gong

Model: MH-SLJL-00

Technical Features

- Designed and manufactured in accordance with FM1055
- Test Standard: FM1055
- Temperature: 0 to 100°C
- Nominal Pressure: 0-300PSI

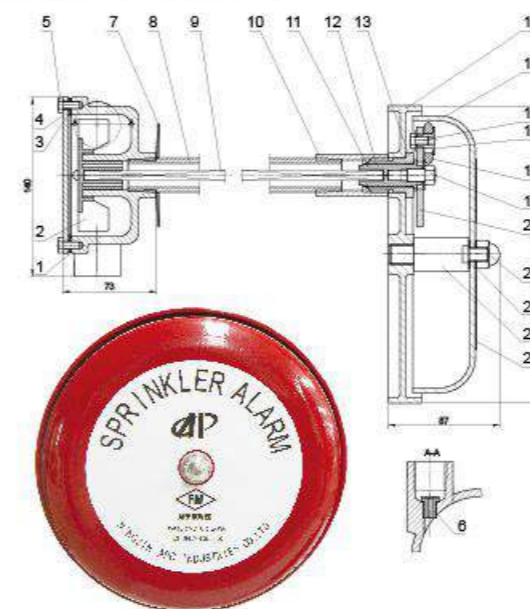

Material List

NO.	Name	Material
1	Driver Shell	Aluminium Alloy
2	Impeller	Delrin
3	Sealing Gasket	Epdm
4	Cover	1045 or SS304
5	Bolt	1045 or SS304
6	Nozzle	C954
7	Gasket	1566
8	Support Pipe	1045 or SS304
9	Drive Shaft	Aluminium Alloy
10	Sleeve	1045 or SS304
11	Internal Circlips	SS304
12	Drive Shaft Adaptor	Delrin
13	Supporting Screw	Aluminium Alloy or SS304
14	Bell Seat	Aluminium Alloy
15	Gong	Aluminium Alloy
16	Bolt	Aluminium Alloy or 1045
17	Support Nut	Aluminium Alloy
18	Striker	Phenolic Resin
19	Bolt	Aluminium Alloy or SS304
20	Joint	Aluminium Alloy
21	Screw Nut	Aluminium Alloy or SS304
22	Gasket	Delrin
23	Supporting Post	Aluminium Alloy or SS304
24	Tag	Paper